

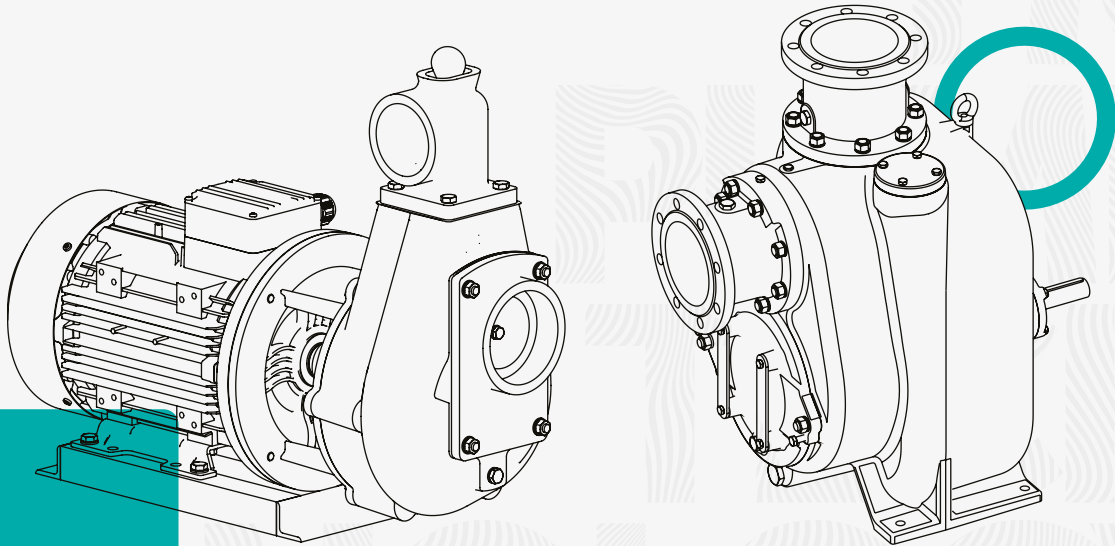

TKF-KE & TKF-E Series

Self Priming Pumps
Kendinden Emişli Pompalar



04.2021 - v1



www.sempapompa.com



power **traction** thrust



IM
PUMP
TECH
NOLOGY

GENERAL INFORMATION

Discharge Flange	4" - 10"
Capacity	up to 840 m ³ /h
Head	up to 42 m
Working Temperature	From -25 °C to + 140 °C *
Casing Pressure (Pmax)	10 bar*

(Pmax: Suction Pressure + Shut off Head)

(*): Depending on the type of liquid, operating temperature and pressure. The pump material changes. Please contact our company for detailed information.

Transferable Liquids

- The impellers are open and have two blades and can pump solid particles up to 76 mm (3") depending on the pump size.

Shaft Sealing

- Mechanical seal is used in standard production.
- It is also possible to use soft packing depending on the customer's request or the type of liquid.

Applications

Domestic and industrial raw sewage liquid transfer	Sewage treatment plants
Liquid transfer containing sludge and solids	Factory waste water drain
	All kinds of drainage operations

Design Features

- TKF-KE and TKF-E series pumps are self-priming centrifugal pumps with flap. Since they are self-priming, it is sufficient that the pump is above the well to be suctioned, only the suction installation is in the well.
- TKF-KE are flange connected, TKF-E series pumps are threaded installation connected.
- TKF-KE series pumps can be driven by diesel engine or electric motor with elastic coupling.
- TKF-E series pumps are connected directly as monoblock to the electric motor with the pump shaft.
- TKF-KE series pumps consist of 4 different types: 4",6",8",10".
- TKF-E series pumps consist of 2 different types: 80-2.5 and 100-3.
- TKF-KE series pumps are open impeller and two vane. TKF-E series pumps have closed impeller.
- TKF-KE series pumps are very easy to unclog. Thanks to the maintenance cover that can be removed from the front, it facilitates access to the impeller, seal box and mechanical seal. It is easy to clear the blockage without any work on the suction and discharge installations.

Pump Code

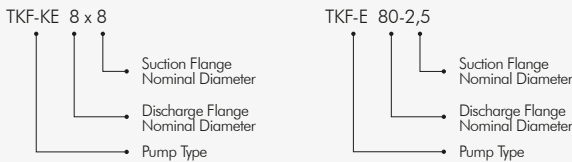

GENEL BİLGİLER

Basma Flaşı	4" - 10"
Debi	840 m ³ /h 'ye kadar
Basma Yüksekliđi	42 m'ye kadar
Çalıřma Sıcaklıđı	-25 °C'den + 140 °C'ye kadar *
Gövde Basıncı (Pmaks)	10 bar*

(Pmaks: Emme Basıncı + Kapalı Vanadaki Basma Yüksekliđi)

(*): Basılan sıvının cinsine, çalıřma sıcaklıđı ve basıncına bađlı olarak pompa malzemeleri deđiřir. Ayrıntılı bilgi için firmamıza bařvurunuz.

Basılabilen Sıvılar

- Çarklar açık ve iki kanatlıdır ve pompa büyüklüđüne göre 76 mm (3") ye kadar katı partikül basabilirler.

Mil Sızdırmazlıđı

- Standart üretimde mekanik salmastra kullanılmaktadır.
- Müřterinin isteđine veya sıvının cinsine göre yumuřak salmastra kullanmak da mümkündür.

Kullanım Yerleri

Evsel ve endüstriyel ham kanalizasyon sıvı transferi	Kanalizasyon arıtma tesisleri
Çamurlu ve katı parça içeren sıvı transferi	Fabrika atık su tahliye
	Her türlü drenaj ve tahliye işlemleri

Tasarım Özellikleri

- TKF-KE ve TKF-E serisi pompalar kendinden emiřli, klapeli santrifüj pompalardır. Kendinden emiřli olduklarından pompa emiř yapılacak kuyunun üzerinde, sadece emme tesisatının kuyu içinde olması yeterlidir.
- TKF-KE flařlı bađlantı, TKF-E serisi pompalar yivli tesisat bađlantısı yapılmaktadır.
- TKF-KE serisi pompalar elastik kaplin vasıtasıyla dizel motor veya elektrik motoru ile tahriki mümkündür.
- TKF-E serisi pompalar direk elektrik motoruna, pompa miliyle monoblok olarak bađlıdır.
- TKF-KE serisi pompalar 4 farklı tipten oluřmaktadır:4",6",8",10".
- TKF-E serisi pompalar 2 farklı tipten oluřmaktadır:80-2.5 ve 100-3.
- TKF-KE serisi pompalar açık çarklı ve iki kanatlıdır. TKF-E serisi pompalar kapalı çarklıdır.
- TKF-KE serisi pompalar tıkanmayı gidermek çok kolaydır. Önden çıkabilen bakım kapađı sayesinde çarka, salmastra kutusuna ve mekanik salmastraya eriřimi kolaylařtırmaktadır. Emme ve basma tesisatlarında herhangi bir işlem yapmadan tıkanıklıđı gidermek kolaydır.

Pompa Kodu

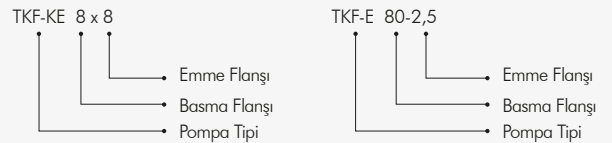

MATERIAL OPTIONS

MALZEME SEÇENEKLERİ

Part List	0.6025	0.7040	0.7043	1.0619	1.4308	1.4309	1.4408	1.4409	1.4500	1.4517	1.4469	1.4317	1.4008	2.1050.01	2.0975.01	2.1096.01	1.0503	1.4021	1.4021+QT	1.4301	1.4404	1.4460	1.4462	1.0037	Parça Listesi
Volute Casing	●	○	○	○	○	○	○	○	○	○	○	○	○	○											Salyangoz Gövde
Stuffing Box	●	○	○	○	○	○	○	○	○	○	○	○	○	○											Salmastra Kutusu
Impeller	●	○	○	○	○	○	○	○	○	○	○	○	○	○	○	○						○			Çark
Shaft																	●	○	○	○	○				Mil
Bearing Housing	●	○	○	○	○	○	○	○																	Rulman Yatağı
Wear Plate																				○	○		●		Aşınma Plakası
Flap						Viton																			Klape
Mechanical Seal																									Mekanik Salmastra

(*) Options: Depending on the customer request or working conditions, different types and brands of mechanical seals or soft packing can be used.

Seçenekler : Alıcının isteğine veya çalışma şartlarına bağlı olarak değişik tip ve markalarda mekanik veya yumuşak salmastra kullanılabilir.

- Standard Manufacturing
○ Optional

- Standart İmalat
○ İsteğe Bağlı

DESCRIPTIONS



TANIM

	DIN	EN	AISI/SAE/ASTM	TANIM
Cast Iron	0.6025	EN-GJL-250 (GG 25)	A 48 Class 40-B	Pik Döküm
Ductile Iron Casting	0.7040	EN-GJS-400-15 (GGG40)	A 536 60-40-18	Sfero Döküm
Ductile Iron Casting	0.7043	EN-GJS-400-18-LT (GGG40.3)	A 536 60-40-18	Sfero Döküm
Steel Casting	1.0619	GP240GHGS-C25	A216 WCB	Çelik Döküm
Chrome Nickel Steel Casting	1.4308	GX5CrNi19-10	A 351 CF8	Krom Nikelli Çelik Döküm
Chrome Nickel Steel Casting (Low Carbon)	1.4309	GX2CrNi19-11	A 351 CF3	Krom Nikelli Çelik Döküm (D. K.)
Chrome Nickel Molybdenum Steel Casting	1.4408	G-X5 Cr Ni Mo 19-11-2	A 351 CF8M	Krom Nikel Molibdenli Çelik Döküm
Chrome Nickel Molybdenum Steel Casting (L.C.)	1.4409	G-X2 Cr Ni Mo 19-11-2	A 351 CF3M	Krom Nikel Molibdenli Çelik Döküm (D.K.)
Austenitic Steel Casting	1.4500	GX7NiCrMoCuNb25-20	A 351 CN7M	Östenitik Çelik Döküm
Austenitic - Ferritic Steel Casting (Duplex)	1.4517	G-X2 Cr Ni Mo Cu N 25-6-3-3	A 890 CD4MCuN	Östenitik-ferritik Çelik Döküm (D.)
Austenitic - Ferritic Steel Casting (S.D.)	1.4469	G-X2 Cr Ni Mo N 26-7-4	A 890 CE3MN	Östenitik-ferritik Çelik Döküm (S.D.)
Martensitic Stainless Steel Casting	1.4317	G-X4 Cr Ni 13-4	A 352 CA6NM	Martenzitik Paslanmaz Çelik Döküm
Martensitic Stainless Steel Casting	1.4008	G-X7 Cr Ni Mo 12-1	A 217 CA15	Martenzitik Paslanmaz Çelik Döküm
Bronze Casting (Tinned)	2.1050.01	G-Cu Sn 10	B 427 C90700	Bronz Döküm (Kalaylı)
Bronze Casting (Nickel Alloy)	2.0975.01	G-Cu Al10 Ni	B 148 C95500	Bronz Döküm (Nikel Alaşımı)
Bronze Casting (Leaded)	2.1096.01	G-Cu Sn 5 Zn Pb	B 584 C83600	Bronz Döküm (Kurşunlu)
Carbon Steel	1.0503	C 45	AISI 1045	Karbonlu Çelik
Chromium Steel	1.4021	X20 Cr13	A 276 Type 420	Kromlu Çelik
Chrome Steel (Heat Treatment)	1.4021	X20 Cr13	A 276 Type 420+QT	Krom Nikel Çelik (Isıl İşlem)
Chrome Nickel Steel	1.4301	X5 Cr Ni 18-10	A 276 Type 304	Krom Nikel Çelik
Chrome Nickel Molybdenum Steel (L.C.)	1.4404	X2 Cr Ni Mo 17-12-2	A 276 Type 316L	Krom Nikel Molibdenli Çelik (D.K.)
Duplex (Austenitic-Ferritic) Steel	1.4460	X3 Cr Ni Mo N 27-5-2	AISI 329	Dubleks (Östenitik-Ferritik) Çelik
Duplex (Austenitic-Ferritic) Steel	1.4462	X2 Cr Ni Mo N 22-5-3	UNS S32205	Dubleks (Östenitik-Ferritik) Çelik



TKF-KE 4x4

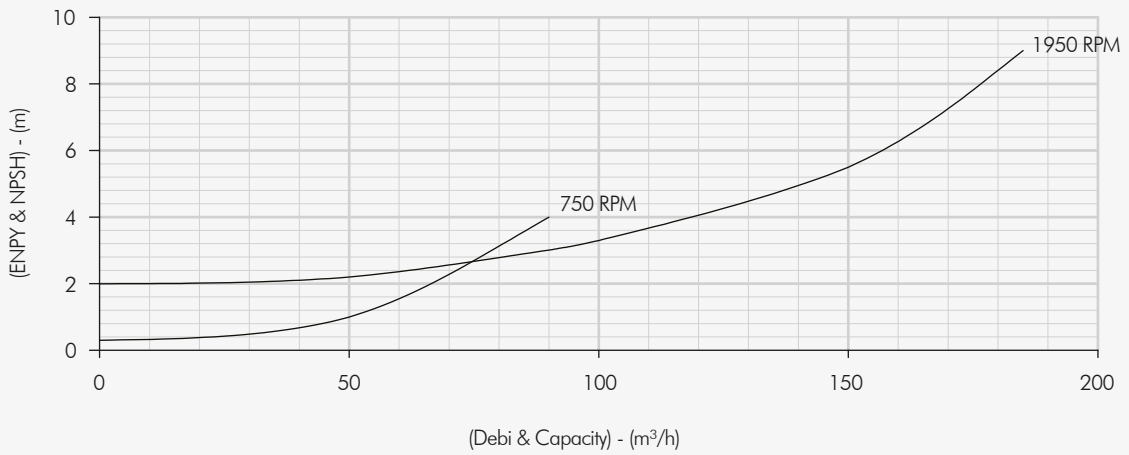
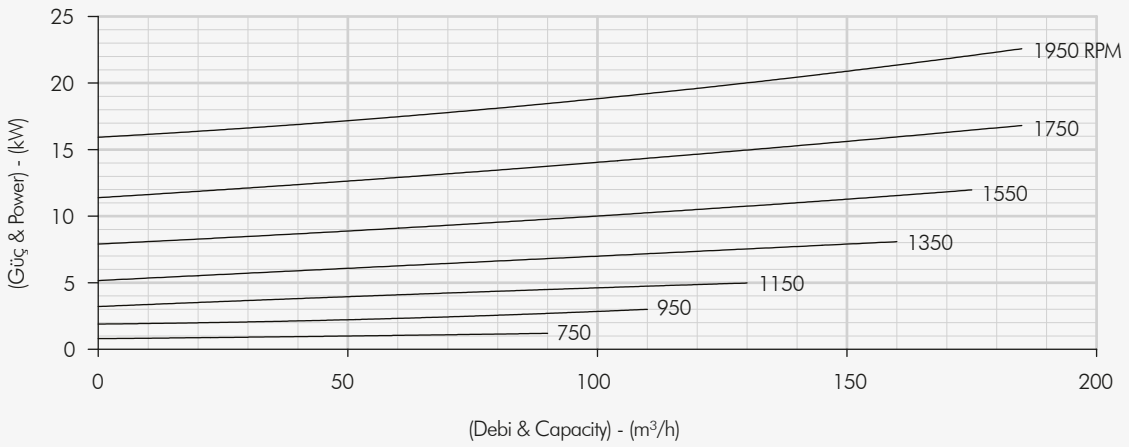
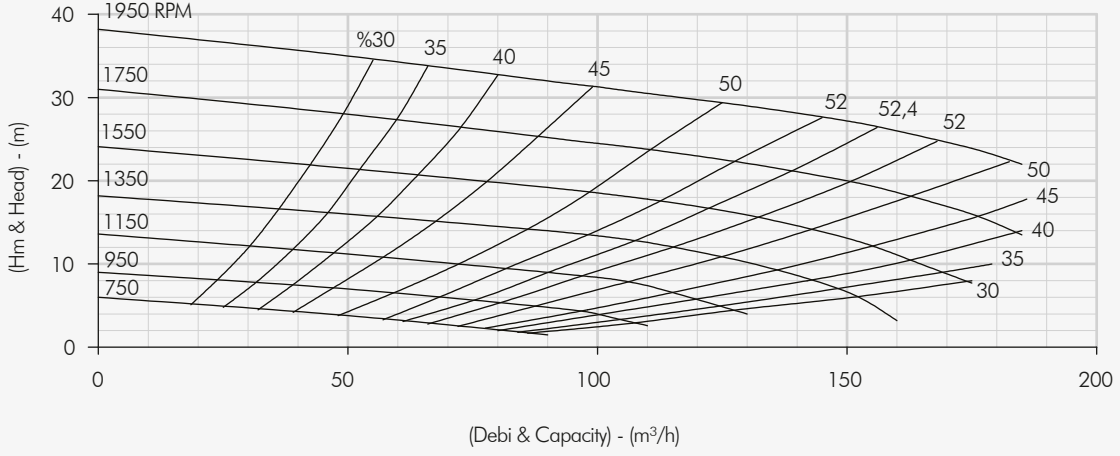

TKF-KE 6x6

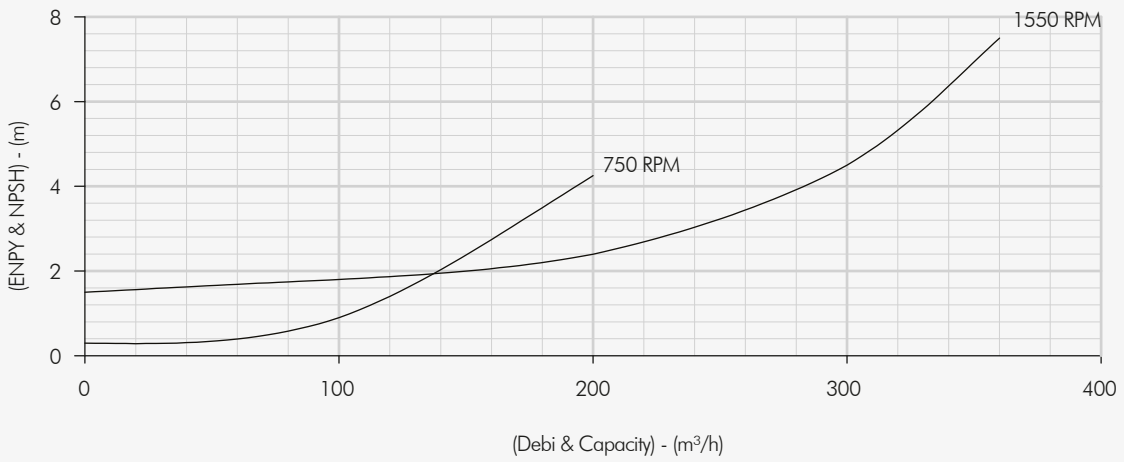
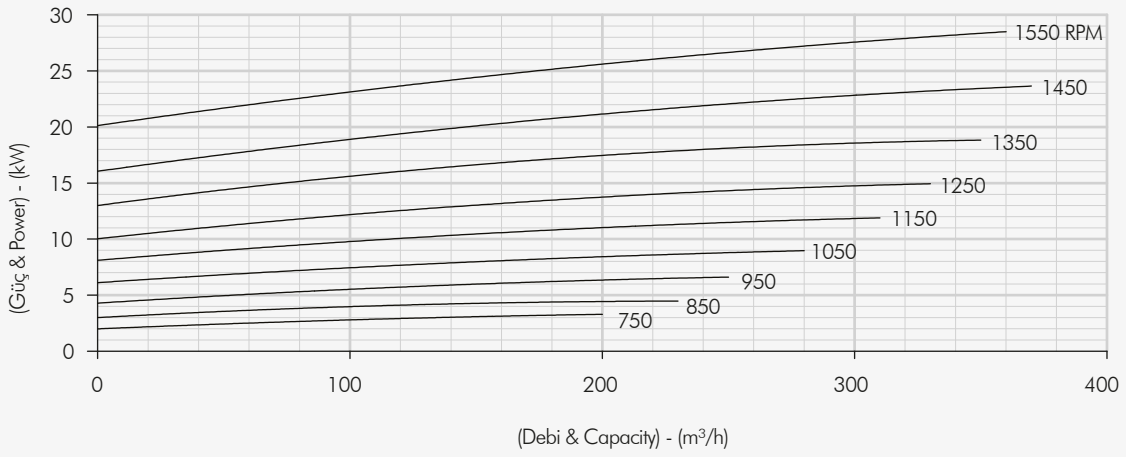
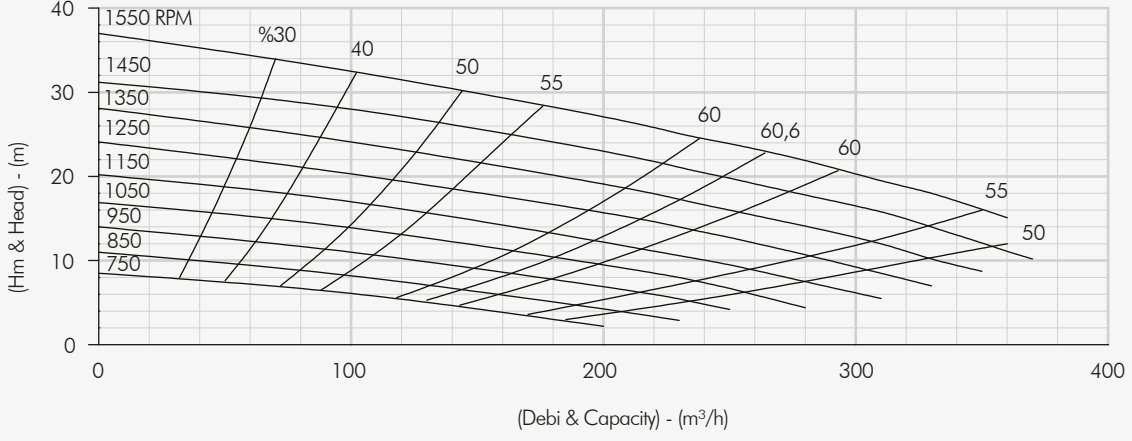

TKF-KE 8x8

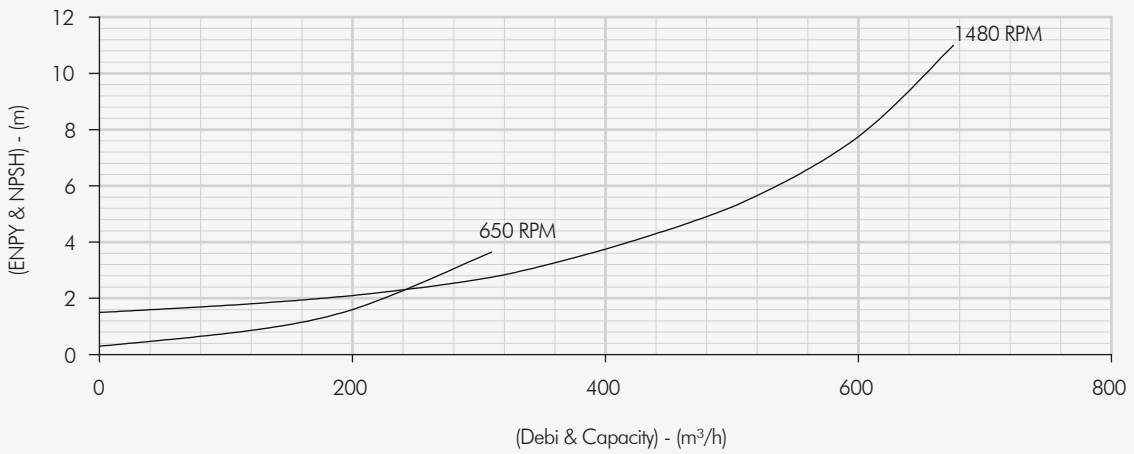
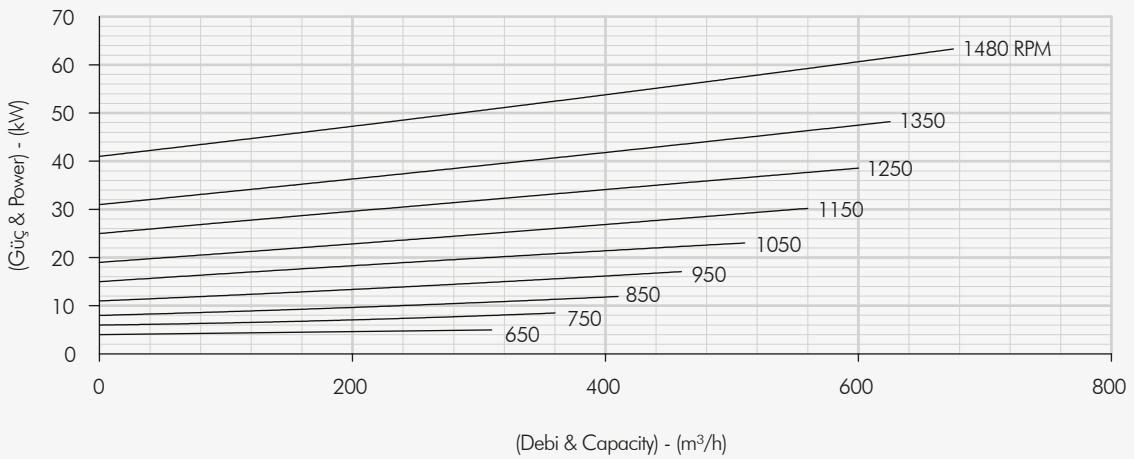
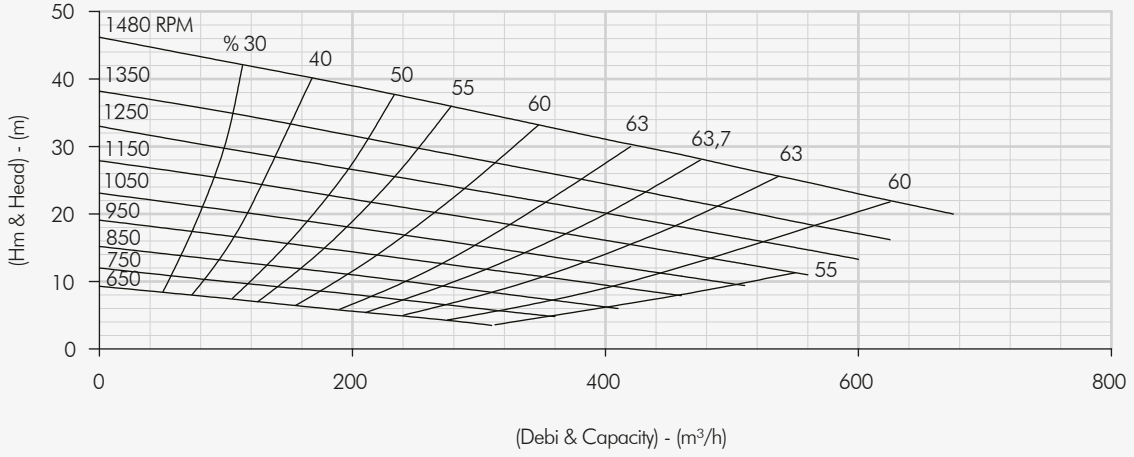

TKF-KE 10x10

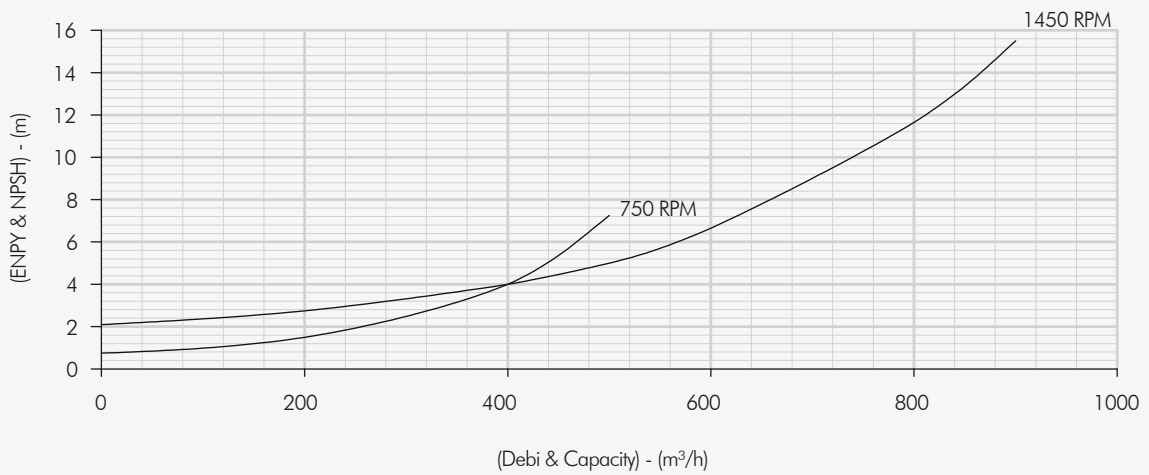
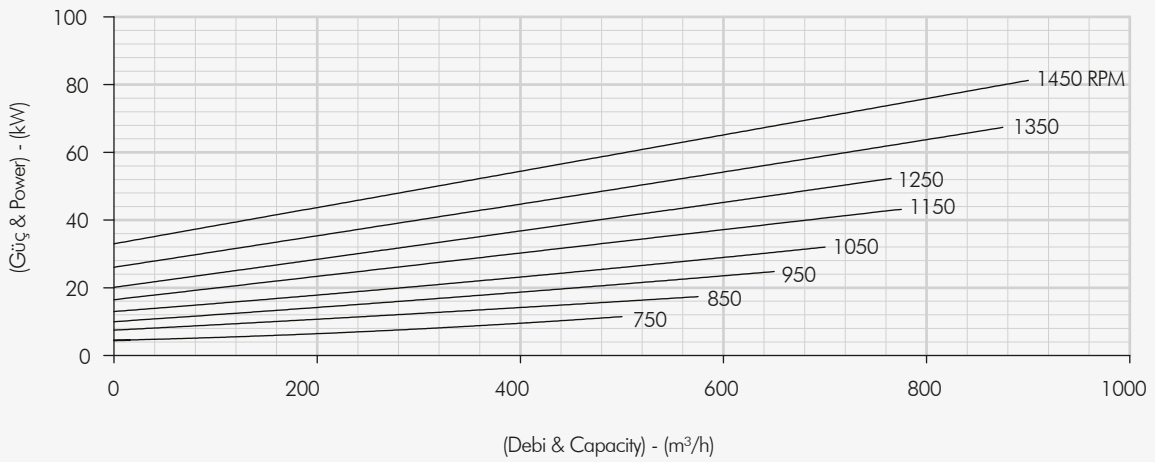
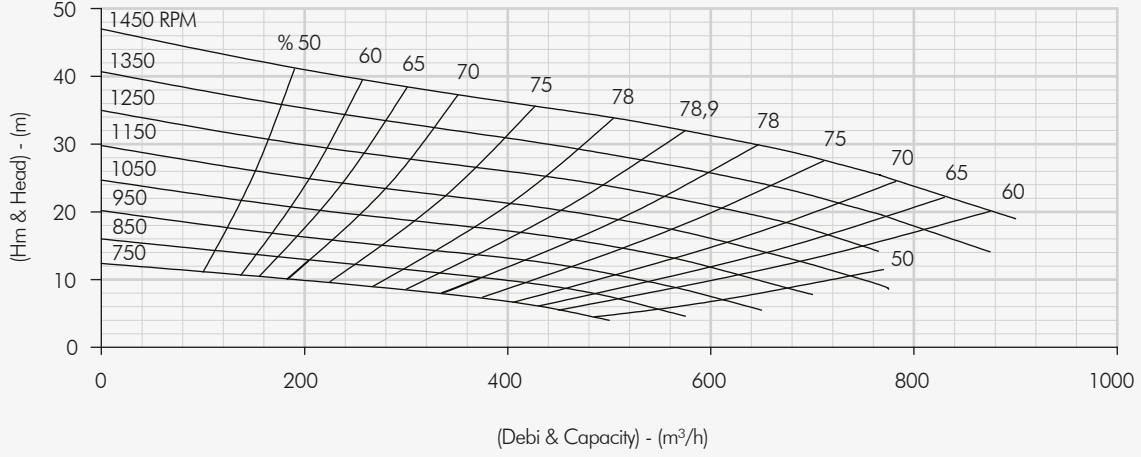

TKF-E 80x2,5

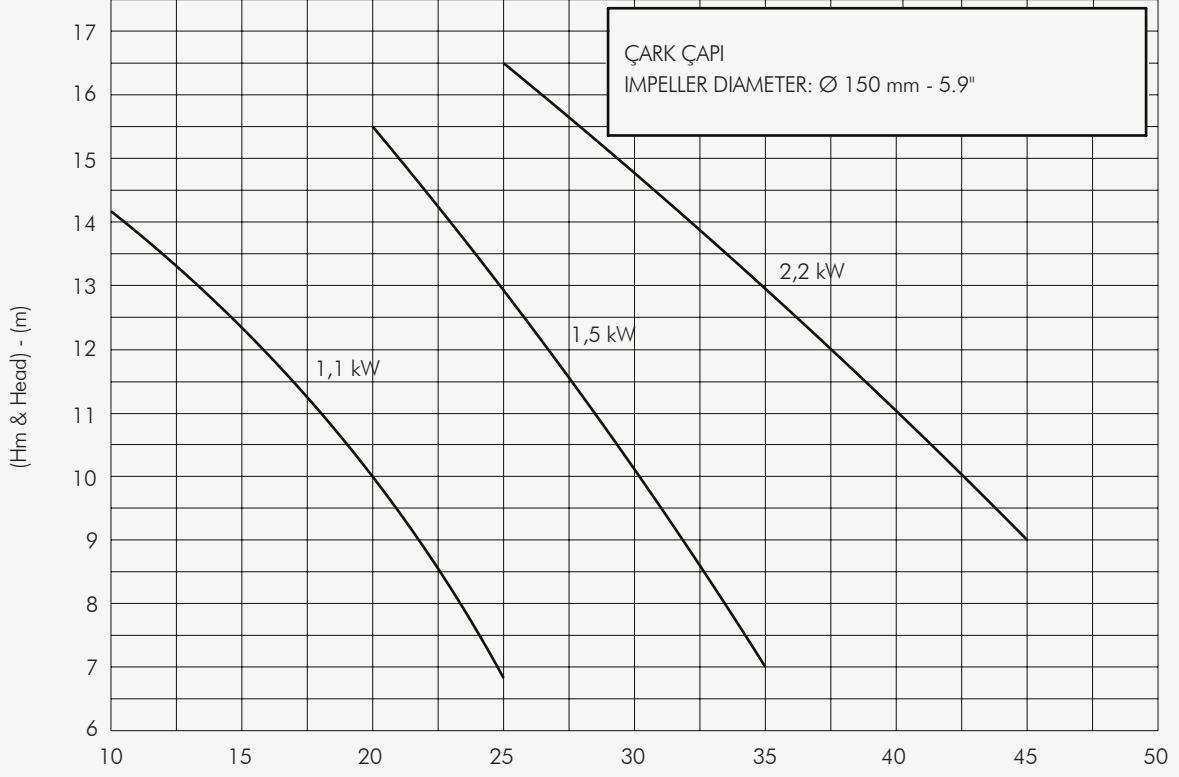

TKF-E 100X3

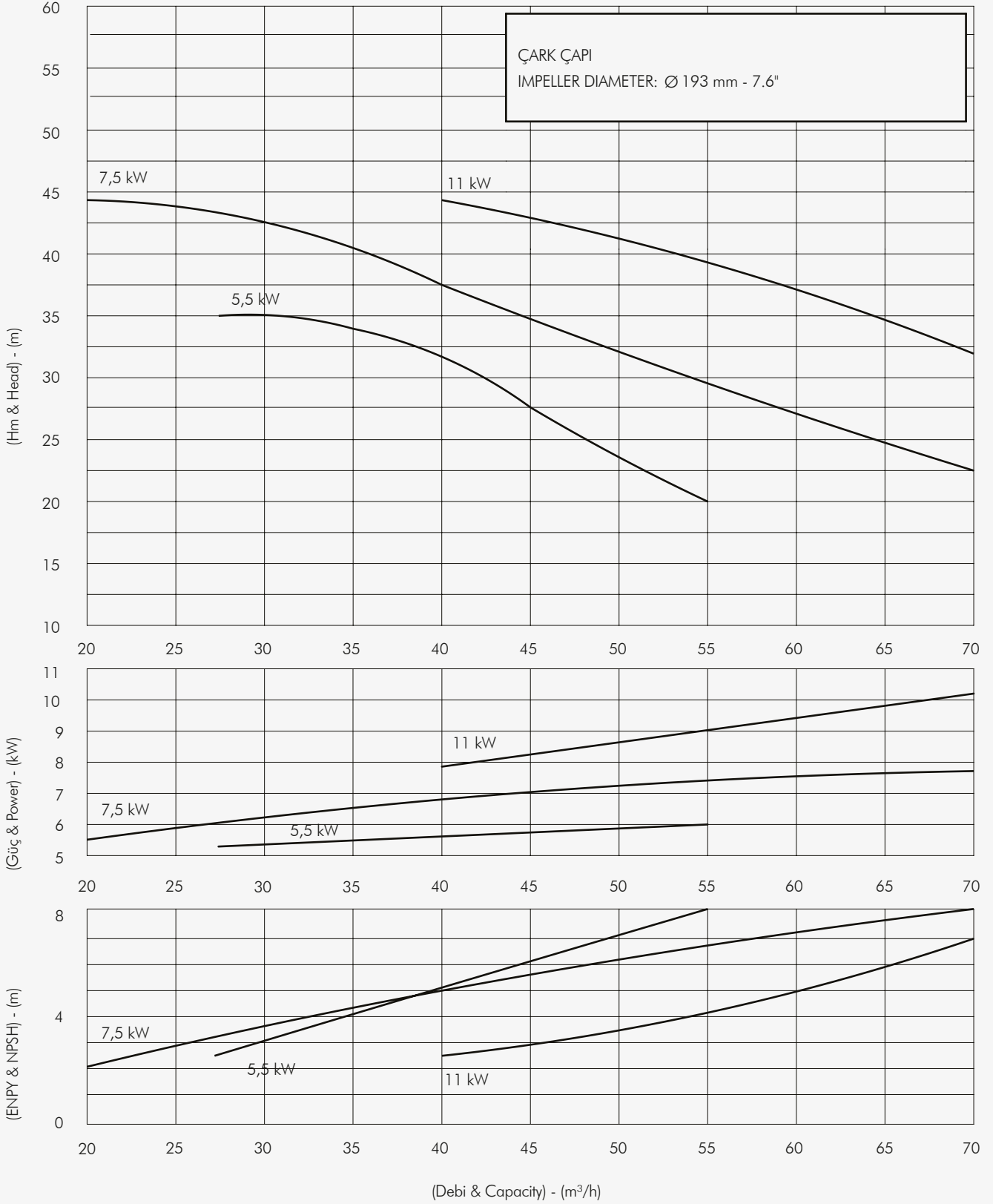

TKF-KE 4x4 6x6 8x8

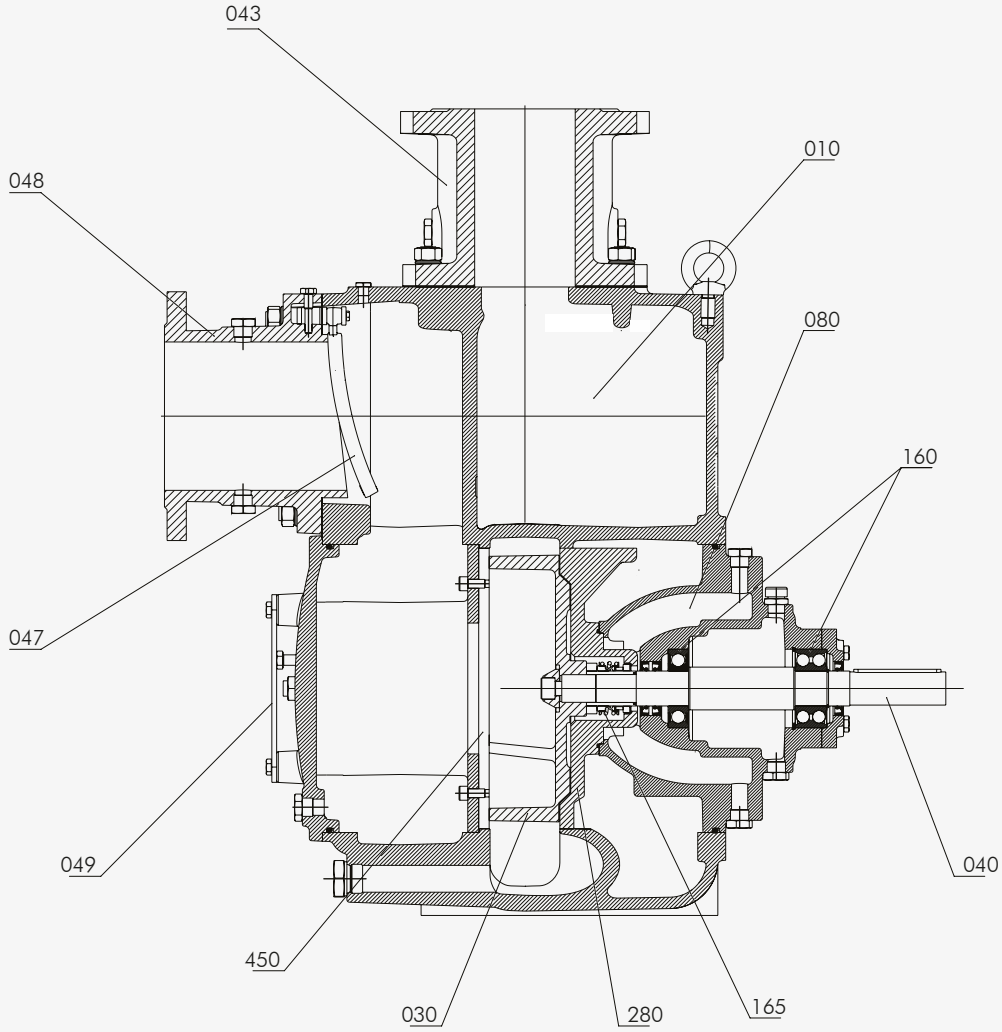

Part List

Parça Listesi

Shaft	040	Mil
Mechanical Seal	165	Mekanik Salmastra
Impeller	030	Çark
Wear Plate	450	Aşınma Plakası
Cover Carrying Plate	049	Kapak Taşıma Sacı
Flap	047	Klape
Suction Flange	048	Emme Flanşı
Discharge Flange	043	Basma Flanşı
Volute Casing	010	Salyangoz Gövde
Bearing Housing	080	Rulman Yatağı
Bearing	160	Rulman

TKF-KE 10x10

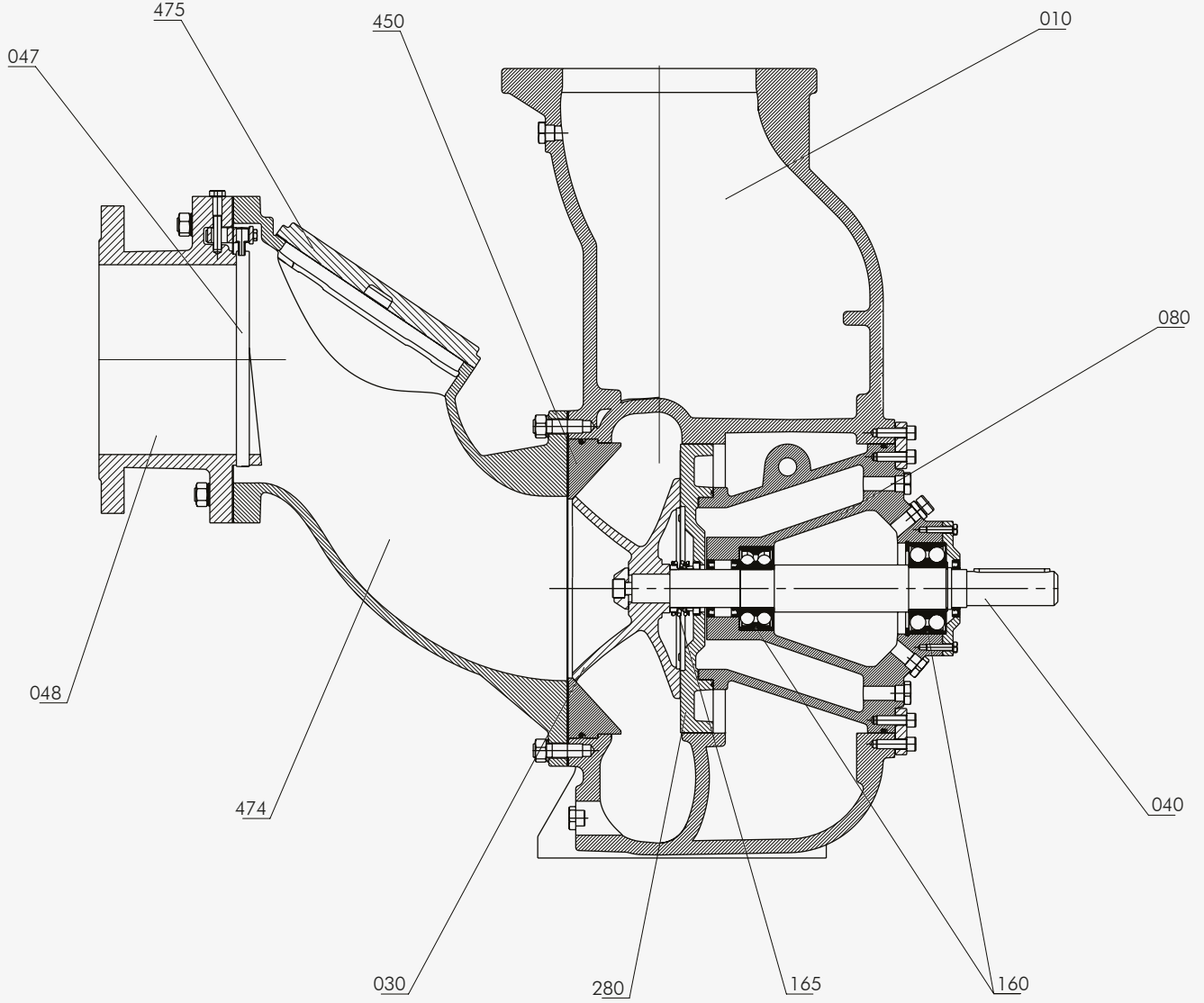

Part List

Parça Listesi

Shaft	040	Mil
Mechanical Seal	165	Mekanik Salmastra
Stuffing Box	280	Salmastra Kutusu
Impeller	030	Çark
Wear Plate	450	Aşınma Plakası
Flap	047	Klape
Suction Flange	048	Emme Ağız
Inlet Elbow	474	Giriş Dirseği
Inlet Elbow Cover	475	Giriş Dirseği Kapağı
Volute Casing	010	Salyangoz Gövde
Bearing Housing	080	Rulman Yatağı
Bearing	160	Rulman

TKF-E 80X2,5 TKF-E 100X3

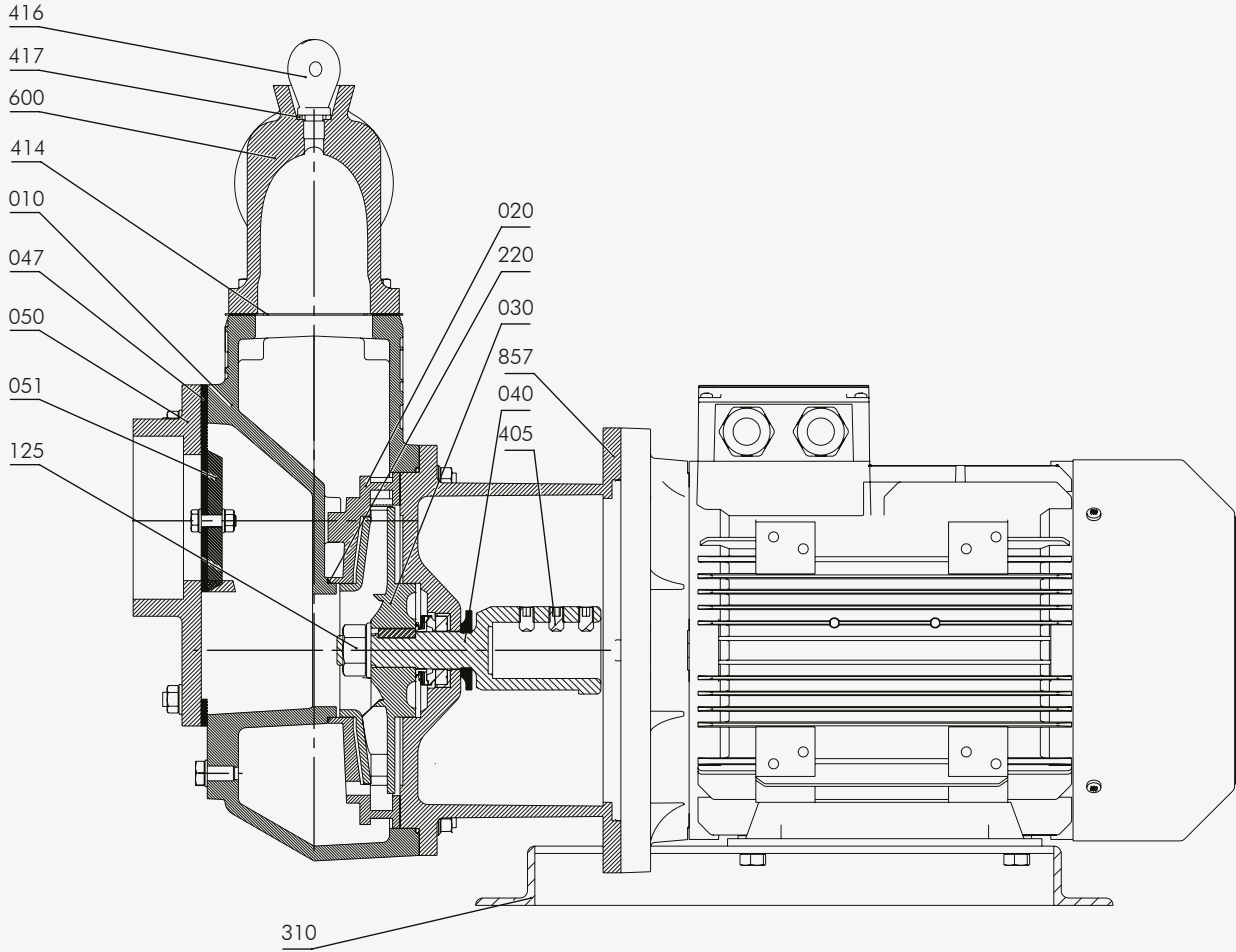

Part List

Parça Listesi

Volute Casing	010	Salyangoz Gövde
Diffuser	020	Difüzör
Impeller	030	Çark
Pump Shaft	040	Pompa Mili
Flap	047	Klape
Suction Flap Cover	050	Emme Klape Kapağı
Flap Weight Washer	051	Klepe Ağırlık Pulu
Mechanical Seal	165	Mekanik Salmastra
O-Ring	220	O-Ring
Lower Table	310	Alt Tabla
Cylinder Head Gasket	414	Klingirt Conta
Thread Butterfly Screw	416	Diş Kelebek Vida
Gasket Butterfly Screw	417	Conta-Kelebek Vida
Elbow Pressure Flange	600	Dirsekli Basma Flaşı
Motor Carrier	857	Motor Taşıyıcı

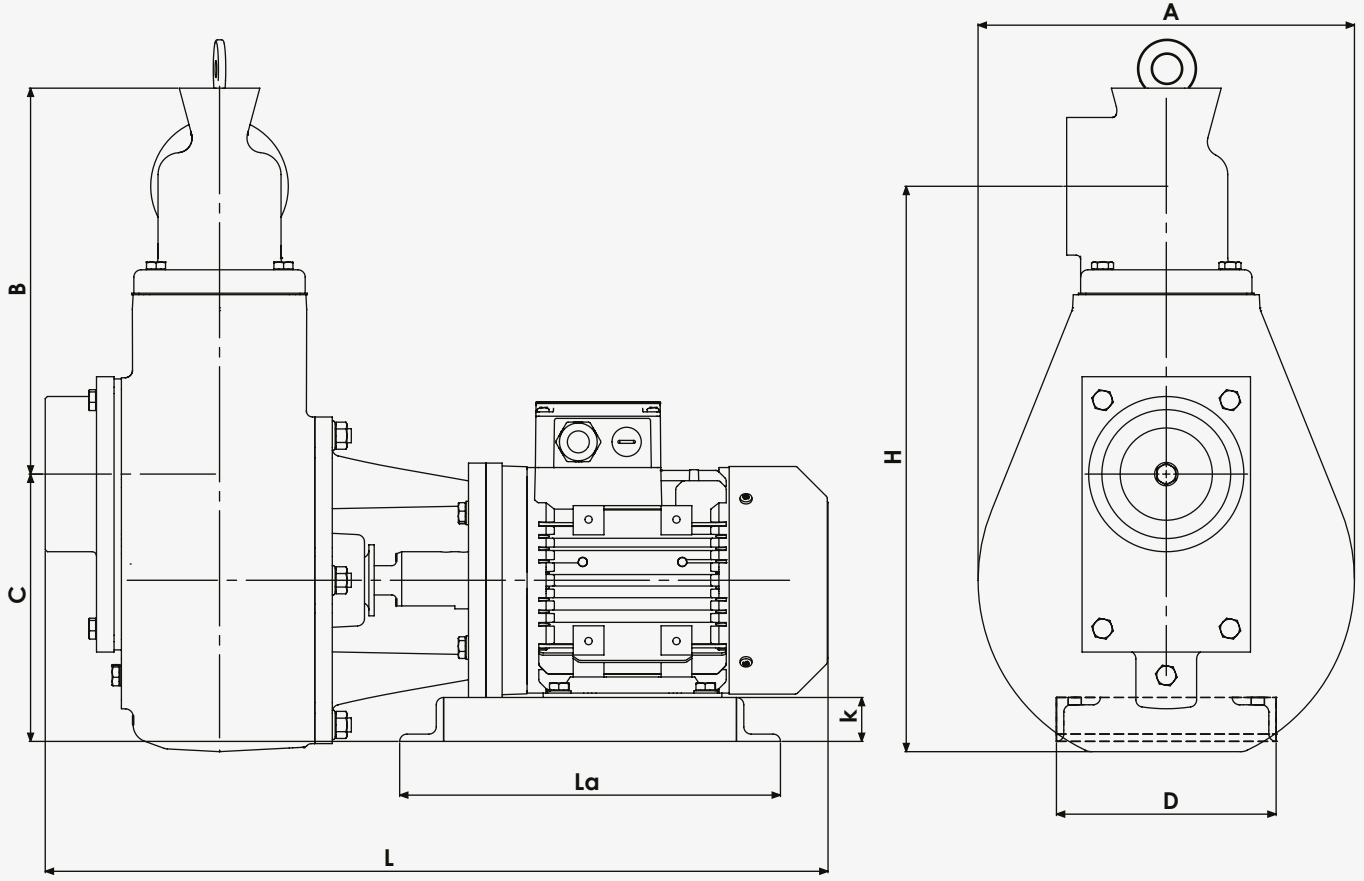

Pump Type Pompa Tipi	Basma Ağızı (İnc)	Emme Ağızı (İnc)	Motor Gücü (İnc)	Devir (rpm)	Ölçüleri (mm)								Weight Ağırlık (kg)
					A	B	C	D	H	L	La	k	
80-2.5	2.5	3	1.1	3000	257	264	182	150	386	543	260	30	45
80-2.5	2.5	3	1.5	3000	257	264	192	170	386	575	310	30	50
80-2.5	2.5	3	2.2	3000	257	264	192	170	386	575	310	30	51
100-3	3	4	5.5	3000	312	293	262	260	457	743	430	40	93
100-3	3	4	7.5	3000	312	293	262	260	457	743	430	40	98
100-3	3	4	11	3000	312	293	262	260	457	743	430	40	105

TKF-KE 4x4 6x6 8x8

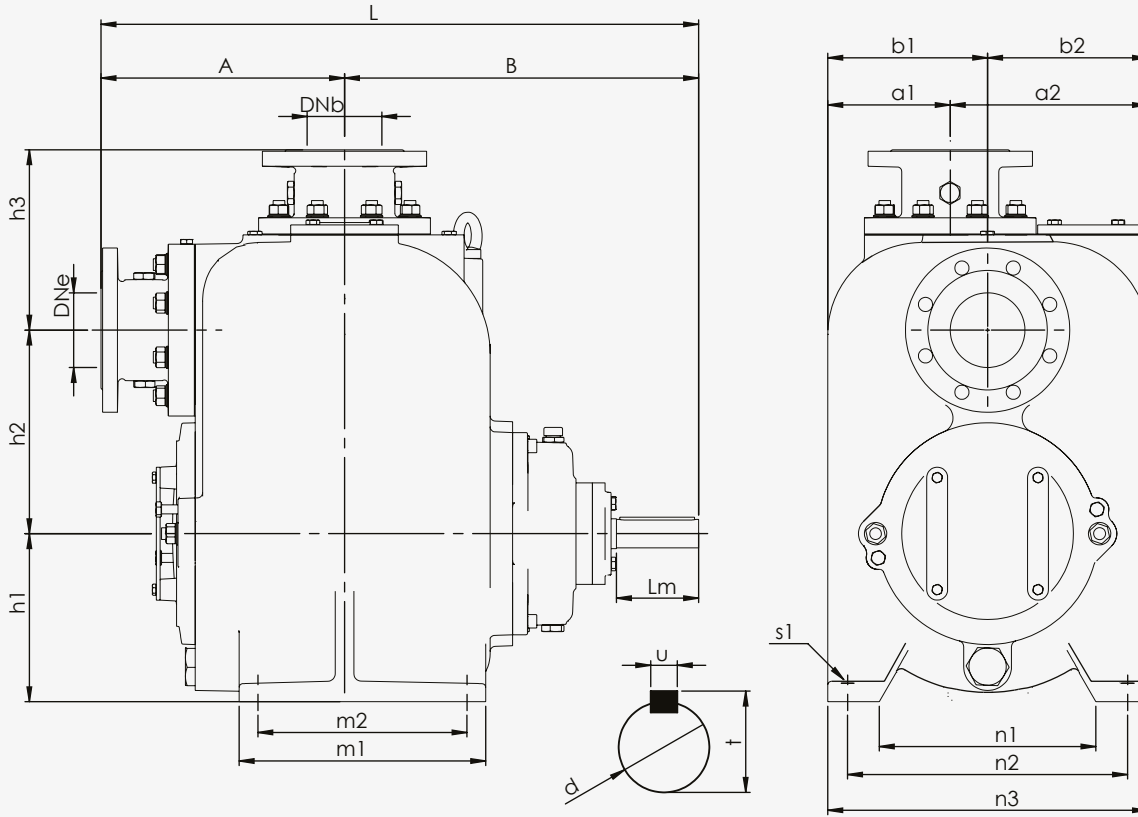

Pump Type Pompa Tipi	Dimensions / Ölçüler (mm)																						Weight Ağırlık (kg)
	Outside Dimensions / Dış Ölçüler								Supporting Foot Dimensions / Ayak Bağlantı Ölçüleri								Shaft Dimensions Mil Ölçüleri						
	DNe	DNb	A	B	L	h1	h2	h3	a1	a2	b1	b2	n1	n2	n3	m1	m2	s1	d	Lm	t	u	
TKF-KE 4x4	100	100	326	474	800	225	273	242	164	264	214	214	428	375	290	330	280	18	38	110	41	10	255
TKF-KE 6x6	150	150	413	482	895	260	312	352	231	356	294	294	423	520	585	340	280	18	38	110	41	10	395
TKF-KE 8x8	200	200	423	559	982	335	388	328	358	358	358	358	549	630	717	385	305	22	45	120	48,5	14	666



TKF-KE 10x10

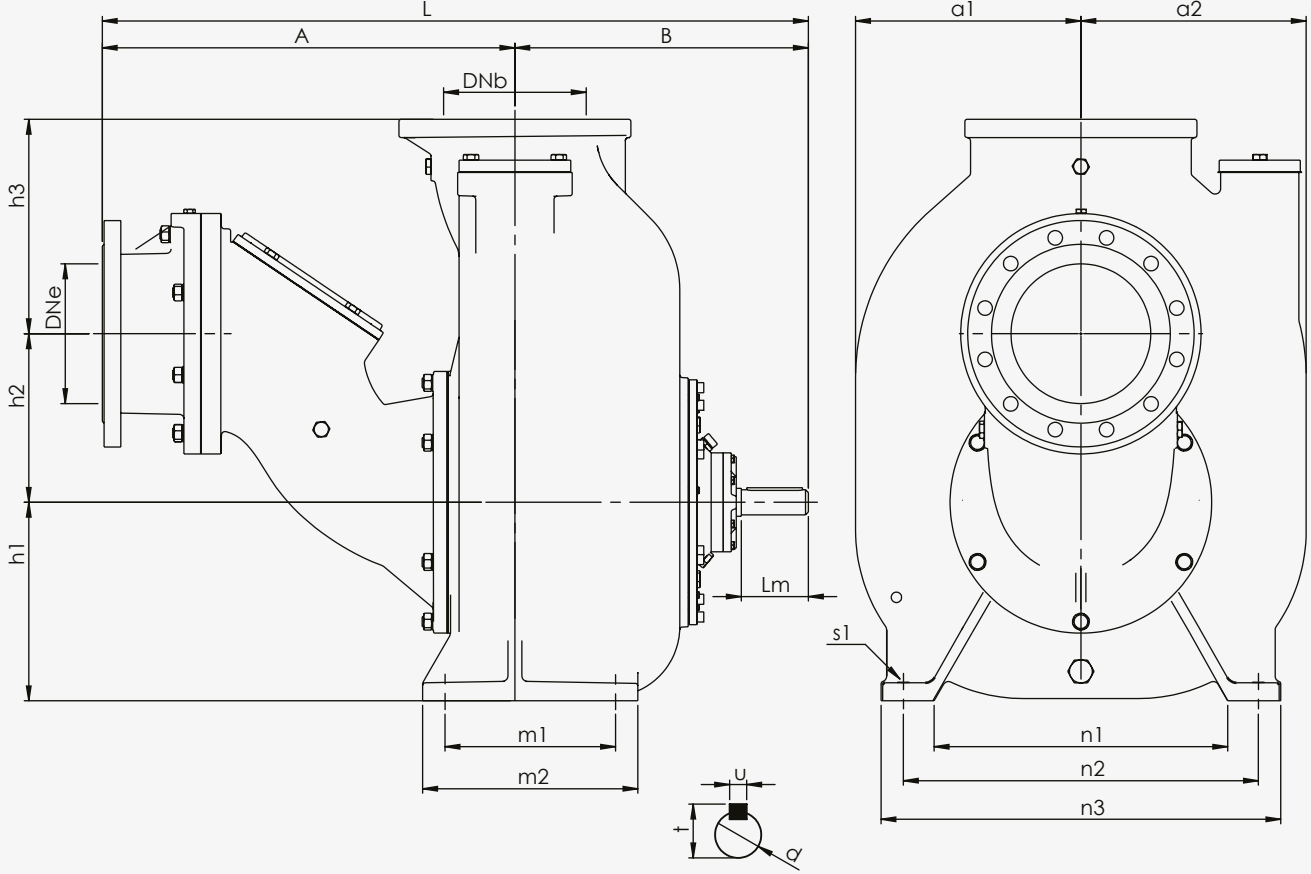

Pump Type Pompa Tipi	Dimensions / Ölçüler (mm)																				Weight Ağırlık (kg)
	Outside Dimensions / Dış Ölçüler							Supporting Foot Dimensions / Ayak Bağlantı Ölçüleri							Shaft Dimensions / Mil Ölçüleri						
	DNe	DNb	A	B	L	h1	h2	h3	a1	a2	n1	n2	n3	m1	m2	s1	d	Lm	t	u	
TKF-KE 10x10	250	250	738	525	1263	355	302	384	403	403	525	635	715	305	385	22	45	120	48,5	14	742



FLANGE DIMENSIONS

FLANŞ ÖLÇÜLERİ

Pump Type Pompa Tipi	DNe / DNb	PN	Suction & Discharge / Emme & Basma			
			Df	k	s	n
TKF-KE 4x4	100	16	220	180	19	8
TKF-KE 6x6	150	16	285	240	23	8
TKF-KE 8x8	200	10	340	295	23	8
TKF-KE 10x10	250	16	405	355	28	12

○ TS EN 1092 - 2 ○ "n" Number of Holes / Delik Sayısı

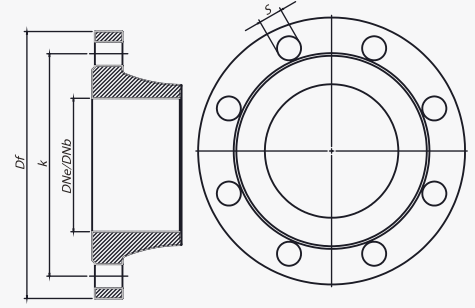

SEAL SOLUTIONS

SALMASTRA ÇÖZÜMLERİ

Packing Type / Salmastra Tipi	Packing Specifications / Salmastra Özellikleri	
	Temperature / Sıcaklık	Pressure / Basınç
MG1	t = -20 °C ... +85 °C t = +85 °C ... +100 °C (*)	p1 = 16 bar (230 PSI) p1 = 16 bar (230 PSI) (*)
H12N	t = +100 °C ... +140 °C	p1 = 25 bar (363 PSI)
M7N	t = -20 °C ... +220 °C	p1 = 25 bar (363 PSI)
Soft Packing / Yumuşak Salmastra	t = -20 °C ... +100 °C	p1 = 10 bar (145 PSI)
	t = -20 °C ... +140 °C (*)	p1 = 25 bar (230 PSI) (*)
CARTEX - DN	t = -20 °C ... +220 °C	p1 = 25 bar (363 PSI)

○ (*) Optional

(*) Opsiyonel ○

*Note: Above datas mentioned according to BURGMANN Brand.
Packing can be changed according to customer request.

*Not: BURGMANN marka mekanik salmastraya göre belirlenmiştir. Müşteri isteğine göre salmastra marka değişikliği yapılabilir.

*Different seal application can be used according to liquid specification.

*Akışkan cinsi ve çalışma şartlarına göre farklı salmastra seçenekleri uygulanabilir.

MEKANİK SALMASTRA

KATI PARTAKÜL GEÇİRKENLİĞİ

Pump Type Pompa Tipi	Mekanik Salmastra Çapı Mechanical Seal Diameter
TKF-E 80-2.5	25
TKF-E 100-3	25
TKF-KE 4x4	40
TKF-KE 6x6	40
TKF-KE 8x8	50
TKF-KE 10x10	50

Pump Type Pompa Tipi	Katı Partakül Geçirgenliği Solid Particle Permeability
TKF-E 80-2.5	7 mm
TKF-E 100-3	11 mm
TKF-KE 4x4	75 mm
TKF-KE 6x6	75 mm
TKF-KE 8x8	75 mm
TKF-KE 10x10	115 mm



50 YIL
50 Years

50 Yıldır Yanınızdayız
We Have Been With You For 50 Years



Pik Döküm
Cast Iron

Paslanmaz Çelik
Stainless Steel

Duplex Çelik
Duplex Steel

KALİTE KONTROL
Quality Control

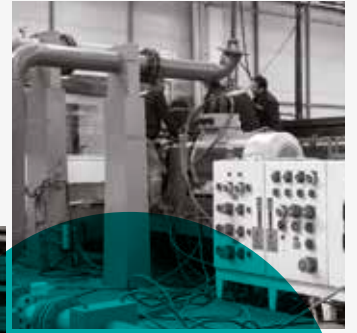

İŞLEME
Machining

CNC - Hassas İşleme - Kalite Kontrol
CNC - Sensitive Machining - Quality Control



DENEY
Testing

Her Ürün İle Test Raporu Teslimi
Supply Testing Raport For Each Pump



STOK
Stock

1.500.000 Kg İşlenmiş Parça
1.500.000 Kg Machined Part

Sfero Döküm
Ductile Cast Iron

Çelik
Steel

Bronz
Bronze



DÖKÜM
Casting

I'M
PUMP
TECH
NOLOGY



TKF-KE & TKF-E SERIES

STORE / MAĞAZA:

Fevzi Çakmak Mh. 10644. Sk. No: 43-45-47 Karatay/Konya, Türkiye
Tel: +90.332 237 03 31
Fax: +90.332 235 43 64
Mail: info@sempapompa.com

FACTORY / FABRİKA:

Büyükkayaçık Osb Mh. 22. Sk. No: 4 Selçuklu/Konya, Türkiye
Tel: +90.332 345 32 90
Fax: +90.332 345 32 95
Mail: info@sempapompa.com

DPT SERIES

ARS-D SERIES

ARS SERIES

TKF-M SERIES

SP SERIES

SCE SERIES