



SEMPA

TKF-AH Series

ISO 2858 Norm Centrifugal Pump

ISO 2858 Norm Santrifüj Pompa

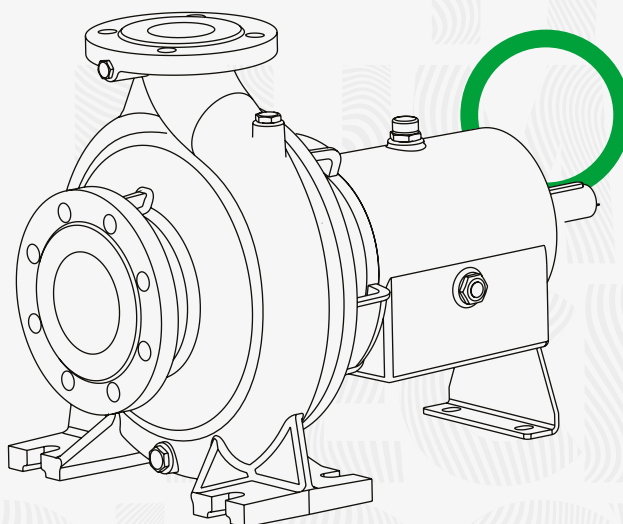

01.2023 - v1



www.sempapompa.com



power **traction** thrust



SEM
PUMPA
TECH
NOLOGY



GENEL MERKEZ - FABRİKA / CENTER - FACTORY

BüyükkayacıkOSB Mh. 22. Sk. No:4 42250
Selçuklu / KONYA / TÜRKİYE
Tel: +90 332 345 32 90 | 444 64 13
E-posta: info@sempapompa.com



SEMPA PLAZA / SEMPA STORE

Fevziçakmak Mh. 10644. Sk. No:43-45-47
Karatay / KONYA / TÜRKİYE
Tel: +90 332 237 03 31
E-posta: info@sempamotor.com

GENERAL INFORMATION

Discharge Flange	DN 32 - DN 250
Capacity	up to 1700 m ³ /h
Head	up to 160 m
Working Temperature	From -25 °C to +140 °C
Casign Pressure (Pmax)	16 bar (25 bar)*

(Pmax: Suction Pressure + Shut off Head)

(*) Depending on the type of liquid, operating temperature and pressure. The pump material changes. Please contact our company for detailed information.

Transferable Liquids

- Clean or slightly contaminated low viscosity liquids without solid & fibrous particles.

Shaft Sealing

- Depending on request or requirement, pumps with soft packing or single, double and catridge type mechanical seals can be supplied.
- External seal cooling system may be used if required.

Applications

Food and Beverage Industry	Paper Industry
Iron and Steel Industry	Chemical Industry
Mining	Oil Industry
Power Plants	Sugar Industry
Fire Fighting	Water Supply

Design Features

- Horizontal, radially split volute casing type, single stage, end suction centrifugal pumps with closed or semi-open impeller.
- In addition to 29 basic sizes conforming with ISO 2858, there are 10 additional sizes. Dimensions of additional sizes may differ from other suppliers.
- Heavy duty shaft not in touch with the medium handled (dry shaft) -Body sealing is ensured by flat gaskets that are not displaced under pressure.
- Suction and discharge flanges conforming to EN 1092-2 / PN 16. (EN 1092-1 / PN 16 for steel or stainless steel casing)
- Due to the back-pull-out design, the complete bearing assembly including impeller and casing cover can be dismantled without removing the volute casing from the piping system. (With spacer coupling application, also possible to take out the rotor group without dismantling the electric motor.)
- All impellers are balanced dynamically or statically according to ISO 1940 class 6.3.
- For closed impellers, axial thrust is balanced by impeller balancing holes system while for semi-open impellers, it is balanced by back ribs.
- Direction of rotation is clockwise viewed from drive end.
- Bearings of TKF-AH type pumps are always oil lubricated.

Pump Code

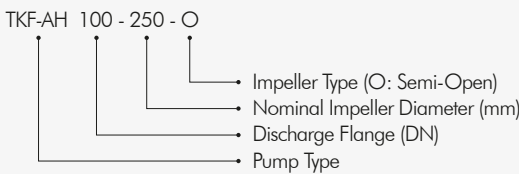

GENEL BİLGİLER

Basma Flaşı	DN 32 - DN 250
Debi	1700 m ³ /h 'ye kadar
Basma Yüksekliği	160 m 'ye kadar
Çalışma Sıcaklığı	-25 °C'den +140 °C'ye kadar*
Gövde Basıncı (Pmaks)	16 bar (25 bar)*

(Pmaks: Emme Basıncı + Kapalı Vanadaki Basma Yüksekliği)

(*) Basılan sıvının cinsine, çalışma sıcaklığı ve basıncına bağlı olarak pompa malzemesi değişir. Ayrıntılı bilgi için firmamıza başvurunuz.

Basılabilen Sıvılar

- İçinde katı parçacıklar ve elyaf bulunmayan, temiz veya çok hafif kirlili, düşük viskoziteli sıvılar.

Mil Sızdırmazlığı

- Basılan sıvının cinsine ve çalışma şartlarına bağlı olarak tekli, çiftli, kartuş tipi mekanik salmastra veya yumuşak salmastra kullanılmaktadır.
- Gerekli durumlarda dış kaynaktan beslenen salmastra soğutması uygulanabilir.

Kullanım Yerleri

Gıda ve İçecek Endüstrisi	Kağıt Endüstrisi
Demir Çelik Endüstrisi	Kimya Endüstrisi
Madencilik	Petrol Endüstrisi
Enerji Santralleri	Şeker Endüstrisi
Yangın Söndürme	Su Temini

Dizayn Özellikleri

- Yatay millili, salyangozlu, tek kademeli, uçtan emişli, kapalı veya yarı açık çarklı santrifüj pompalar.
- Ana boyutları TS EN ISO 2858 Standartlarına uygun 29 adet modele ek olarak 10 adet tamamlayıcı model. Tamamlayıcı modellerin ana boyutları diğer üreticilerinkine göre farklılık gösterebilir.
- Basılan sıvı ile temas etmeyen, kuru çalışan, ağır hizmet tipi mil.
- Gövde sızdırmazlığı, basınç altında yerinden çıkmayacak şekilde yerleştirilmiş düz contalar ile sağlanır.
- Emme ve basma flaşları TS EN 1092 - 2 / PN 16' ya uygundur. (çelik veya paslanmaz çelik gövde malzemeli pompalarda flaşlar TS EN 1092 - 1 / PN 16' ya uygundur.)
- Arkadan sökülebilir tasarım sayesinde, salyangozu boru tesisatından ayırmadan yatak grubu, salmastra yatağı, pompa mili ve çarkı sökülebilir. (İsteğe bağlı olarak ara burçlu kaplin uygulaması ile elektrik motorunu motor taşıyıcıdan ayırmadan da pompanın rotor grubu dışarı alınabilir)
- Bütün çarklar ISO 1940 sınıf 6.3' e uygun dinamik veya statik olarak dengelenmektedir.
- Eksenal kuvvet kapalı çarklarda çark dengeleme delikleri sistemi, yarı açık çarklılarda ise arka kanatçıklar ile dengelenir.
- Dönme yönü motor tarafından bakılınca saat yönündedir.
- TKF-AH tipi pompalarda standart olarak "sıvı yağlı" rulman kullanılmaktadır.

Pompa Kodu

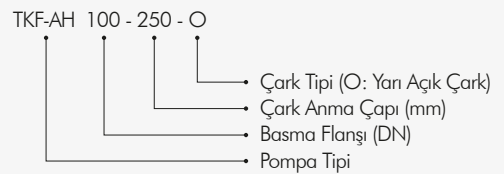

MATERIAL OPTIONS

MALZEME SEÇENEKLERİ

Part List	0.6025	0.7040	0.7043	1.0619	1.4308	1.4309	1.4408	1.4409	1.4500	1.4517	1.4469	1.4317	1.4008	2.1050.01	2.0975.01	1.1096.01	1.4021	1.4021+QT	1.4301	1.4404	1.4460	1.4462	Parça Listesi	
Volute Casing	●	○	○	○	○	○	○	○	○	○	○	○	○	○										Salyangoz Gövde
Seal Box	●	○	○	○	○	○	○	○	○	○	○	○	○	○										Salmastra Kutusu
Impeller	●	○	○	○	○	○	○	○	○	○	○	○	○	○	○	○						○		Çark
Shaft																	●	○	○	○		○		Mil
Bearing Housing	●	○	○	○	○	○	○	○																Rulman Yatağı
Wear Ring	○	○	○	○	○	○	○	○	○	○	○	○	○	○	○	○								Aşınma Halkası
Shaft Wear Bushing																	●	○	○	○		○		Mil Aşınma Burcu
Mech. Seal (*)	EN 12756 / DIN 24960																				Mek. Salmastra (*)			

(*) Options: Different brand and type mechanical seal can be use can according to customer request.

(*) Seçenekler: Alıcının isteğine veya çalışma şartlarına bağlı olarak değişik tip ve markalarda mekanik salmastra kullanılabilir.

- Standard Manufacturing
- Optional

- Standart İmalat
- İsteğe Bağlı

DESCRIPTIONS



TANIM

	DIN	EN	AISI/SAE/ASTM	TANIM
Cast Iron	0.6025	EN-GJL-250 (GG 25)	A 48 Class 40B	Pik Döküm
Ductile Iron Casting	0.7040	EN-GJS-400-15 (GGG40)	A 536 60-40-18	Sfero Döküm
Ductile Iron Casting	0.7043	EN-GJS-400-18-LT (GGG 40.3)	A 536 60-40-18	Sfero Döküm
Steel Casting	1.0619	GP 240 GHGS-C25	A216 WCB	Çelik Döküm
Chrome Nickel Steel Casting	1.4308	GX5 Cr Ni 19-10	A 351 CF8	Krom Nikelli Çelik Döküm
Chrome Nickel Steel Casting (Low Carbon)	1.4309	GX2 Cr Ni 19-11	A 351 CF3	Krom Nikelli Çelik Döküm (D. K.)
Chrome Nickel Molybdenum Steel Casting	1.4408	GX5 Cr Ni Mo 19-11-2	A 351 CF8M	Krom Nikel Molibdenli Çelik Döküm
Chrome Nickel Molybdenum Steel Casting (L.C.)	1.4409	GX2 Cr Ni Mo 19-11-2	A 351 CF3M	Krom Nikel Molibdenli Çelik Döküm (D.K.)
Austenitic Steel Casting	1.4500	GX7 Cr Ni Mo Cu Nb 25-20	A 351 CN7M	Östenitik Çelik Döküm
Austenitic - Ferritic Steel Casting (Duplex)	1.4517	GX2 Cr Ni Mo Cu N 25-6-3-3	A 890 CD4MCuN	Östenitik-ferritik Çelik Döküm (D.)
Austenitic - Ferritic Steel Casting (S.D.)	1.4469	GX2 Cr Ni Mo N 26-7-4	A 890 CE3MN	Östenitik-ferritik Çelik Döküm (S.D.)
Martensitic Stainless Steel Casting	1.4317	GX4 Cr Ni 13-4	A 352 CA6NM	Martenzitik Paslanmaz Çelik Döküm
Martensitic Stainless Steel Casting	1.4008	GX7 Cr Ni Mo 12-1	A 217 CA15	Martenzitik Paslanmaz Çelik Döküm
Bronze Casting (Tinned)	2.1050.01	G-Cu Sn 10	B 427 C90700	Bronz Döküm (Kalaylı)
Bronze Casting (Nickel Alloy)	2.0975.01	G-Cu Al10 Ni	B 148 C95500	Bronz Döküm (Nikel Alaşımı)
Bronze Casting (Leaded)	2.1096.01	G-Cu Sn 5 Zn Pb	B 584 C83600	Bronz Döküm (Kurşunlu)
Chromium Steel	1.4021	X20 Cr13	A 276 Type 420	Kromlu Çelik
Chrome Steel (Heat Treatment)	1.4021	X20 Cr13	A 276 Type 420+QT	Krom Nikel Çelik (Isıl İşlem)
Chrome Nickel Steel	1.4301	X5 Cr Ni 18-10	A 276 Type 304	Krom Nikel Çelik
Chrome Nickel Molybdenum Steel (L.C.)	1.4404	X2 Cr Ni Mo 17-12-2	A 276 Type 316L	Krom Nikel Molibdenli Çelik (D.K.)
Duplex (Austenitic-Ferritic) Steel	1.4460	X3 Cr Ni Mo N 27-5-2	AISI 329	Dubleks (Östenitik-Ferritik) Çelik
Duplex (Austenitic-Ferritic) Steel	1.4462	X2 Cr Ni Mo N 22-5-3	UNS S32205	Dubleks (Östenitik-Ferritik) Çelik



1450 rpm / (d/d) (50 Hz)

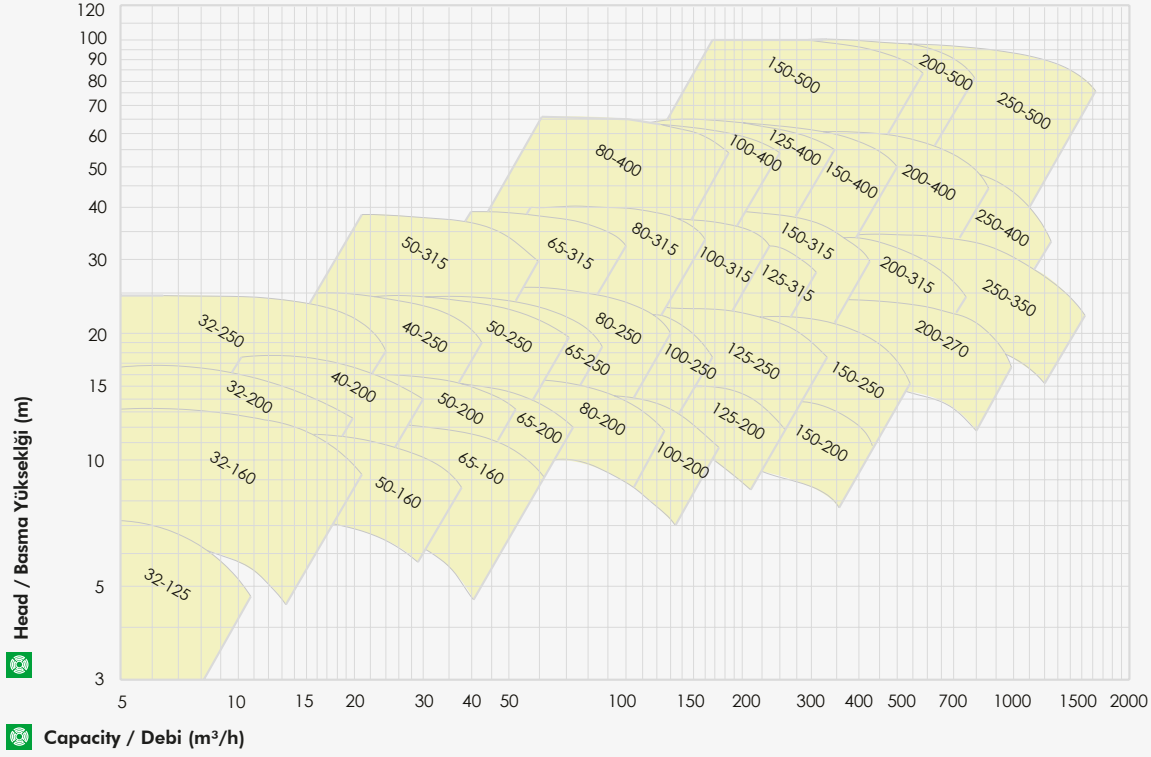

2900 rpm / (d/d) (50 Hz)

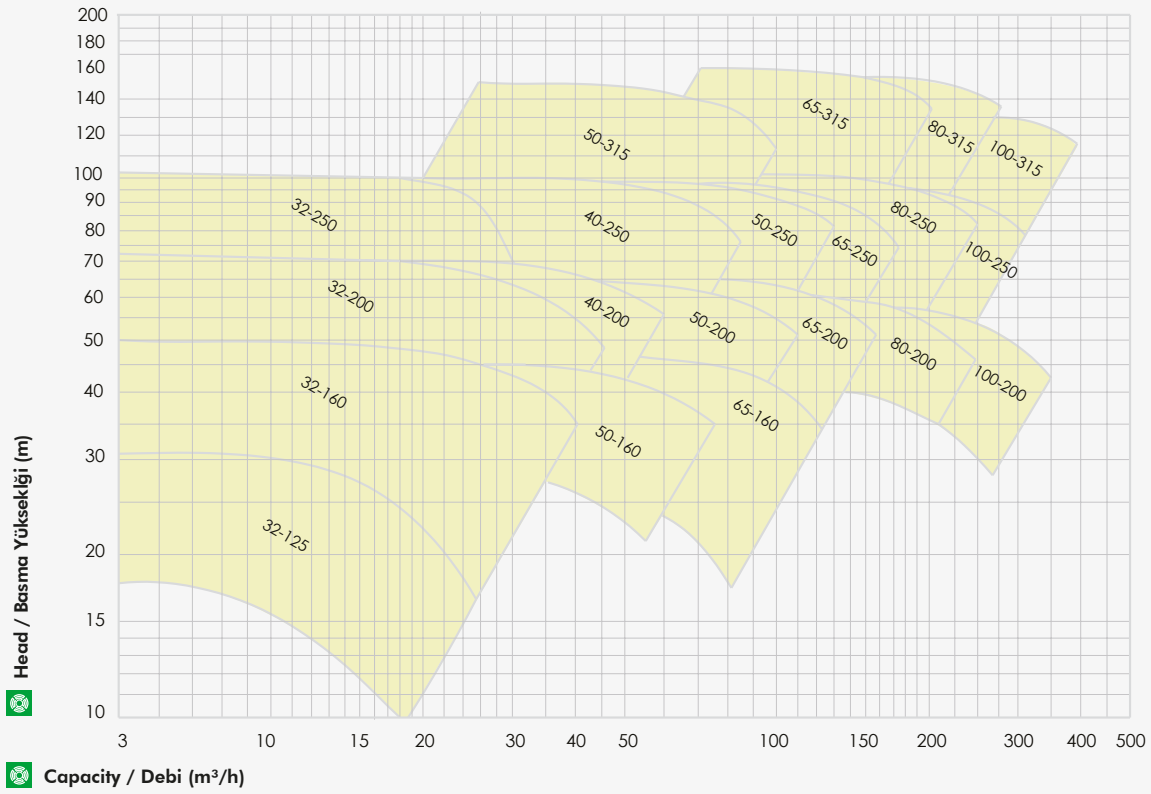

For detailed curves, use our selection program.

Detay eğriler için seçim programımızı kullanınız.



1750 rpm / (d/d) (60 Hz)

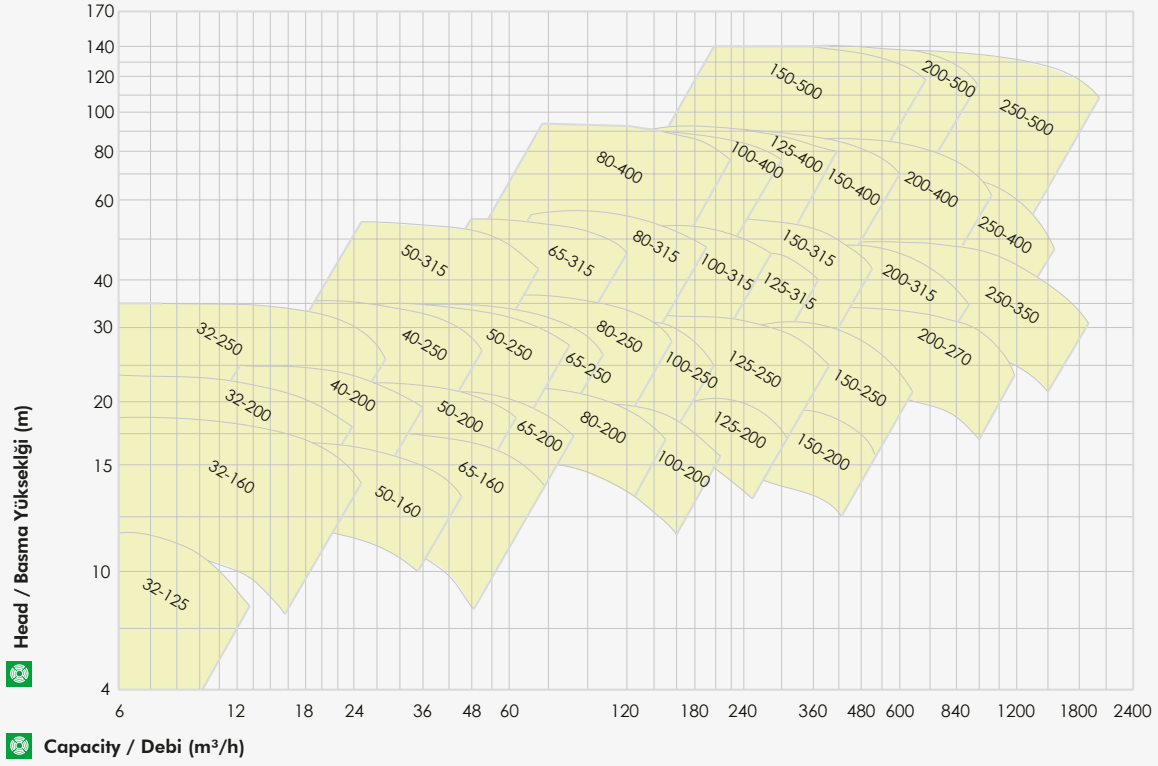

3500 rpm / (d/d) (60 Hz)

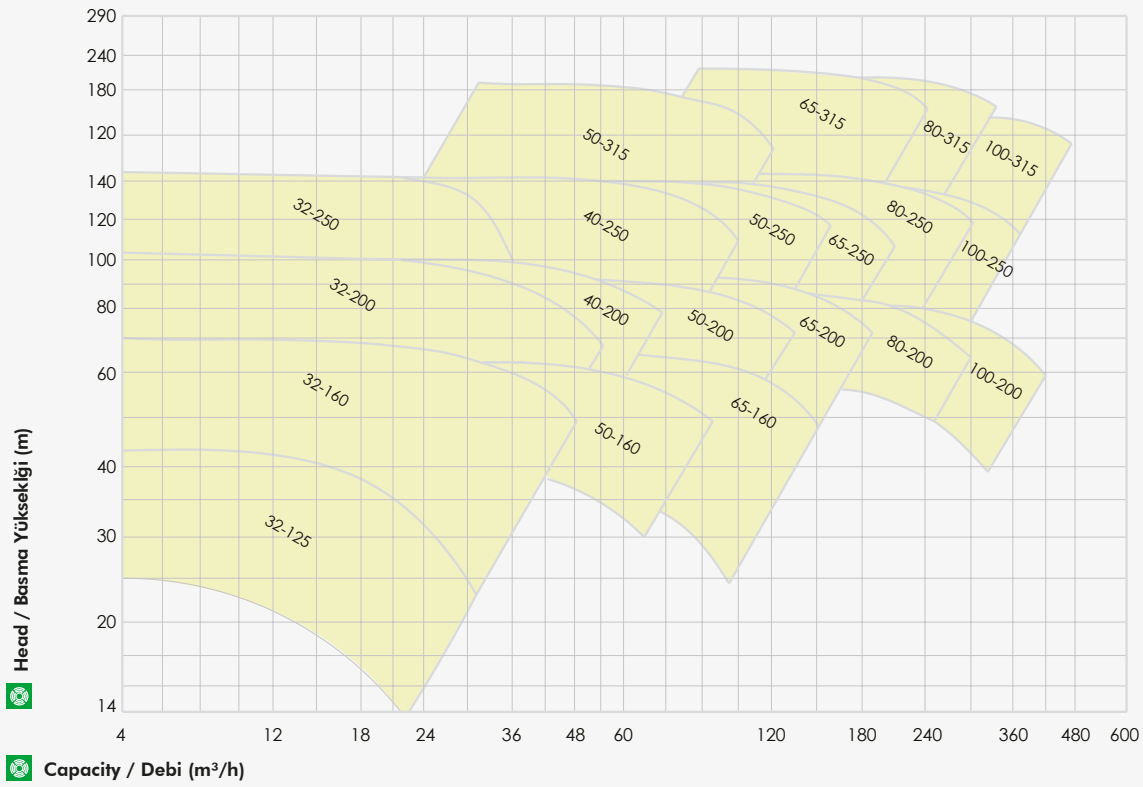
 For detailed curves, use our selection program.

 Detay eğriler için seçim programımızı kullanınız.

SECTIONAL VIEW

KESİT RESİM

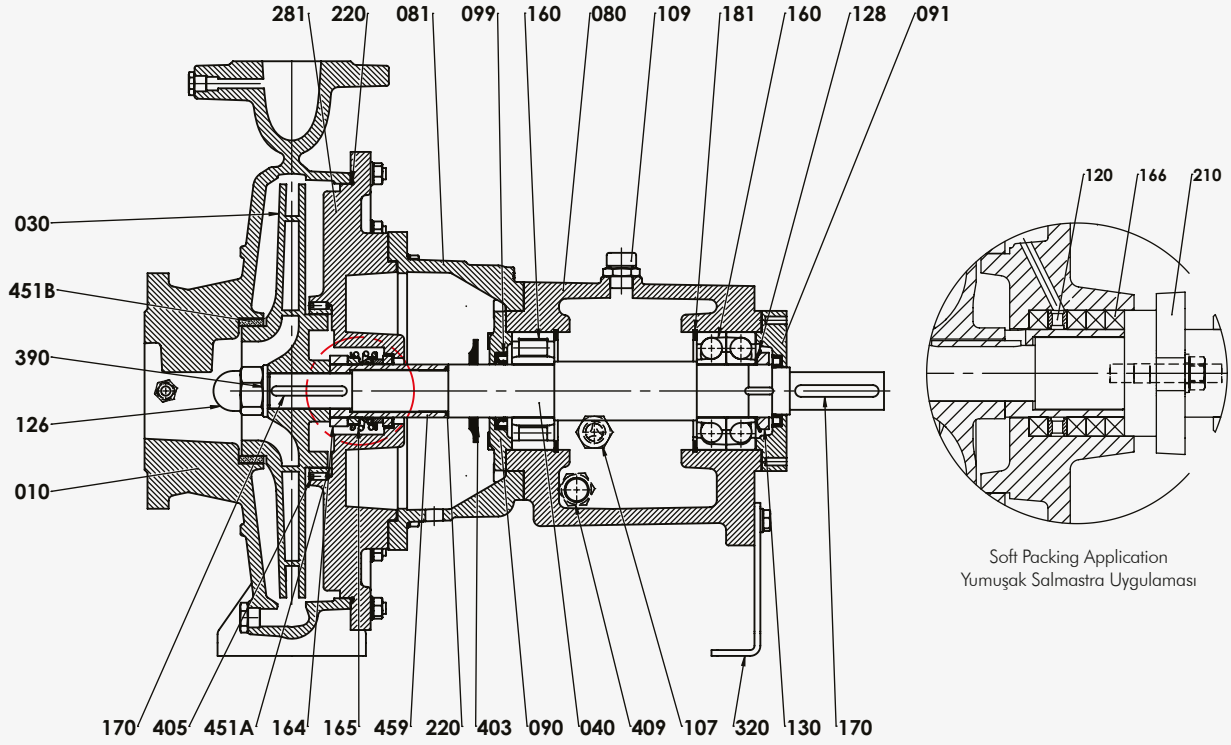

Part List

Parça Listesi

Volute Casing	010	Salyangoz Gövde
Impeller	030	Çark
Shaft	040	Mil
Bearing Housing	080	Rulman Yatağı
Interconnection Part	081	Ara Bağlantı Kafesi
Bearing Cover (Inside)	090	Rulman Kapağı İç
Bearing Cover (Outside)	091	Rulman Kapağı Dış
Oil Seal	099	Yağ Keçesi
Oil Level Indicator	107	Yağ Seviye Göstergesi
Air Bleed Plug	109	Hava Alma Tapası
Flushing Ring	120	Sulama Halkası
Distance Ring	390	Rondela
Closed End Nut	126	Şapkalı Somun
Safety Sheet	128	Emniyet Sacı
Bearing	160	Rulman
Mechanical Seal Setting Sleeve	164	Mekanik Salmastra Mesafe Burcu
Mechanical Seal	165	Mekanik Salmastra
Soft Packing	166	Yumuşak Salmastra
Key	170	Kama
Piston Ring	181	Segman
Connection Support	210	Salmastra Baskısı
O-Ring	220	O-Ring
Seal Box	281	Salmastra Kutusu
Supporting Feet	320	Destek Ayağı
Throw Protection	403	Su Sıçratma Diski
Drain Plug	409	Boşaltma Tapası
Wear Ring (Volute Casing)	451B	Aşınma Halkası (Salyangoz Gövde)
Shaft Sleeve	459	Mil Burcu
Wear Ring (Seal box)	451A	Aşınma Halkası (Salmastra Kutusu)
Lock Nut	130	Çektirme Somunu
Setscrew	405	Setskur



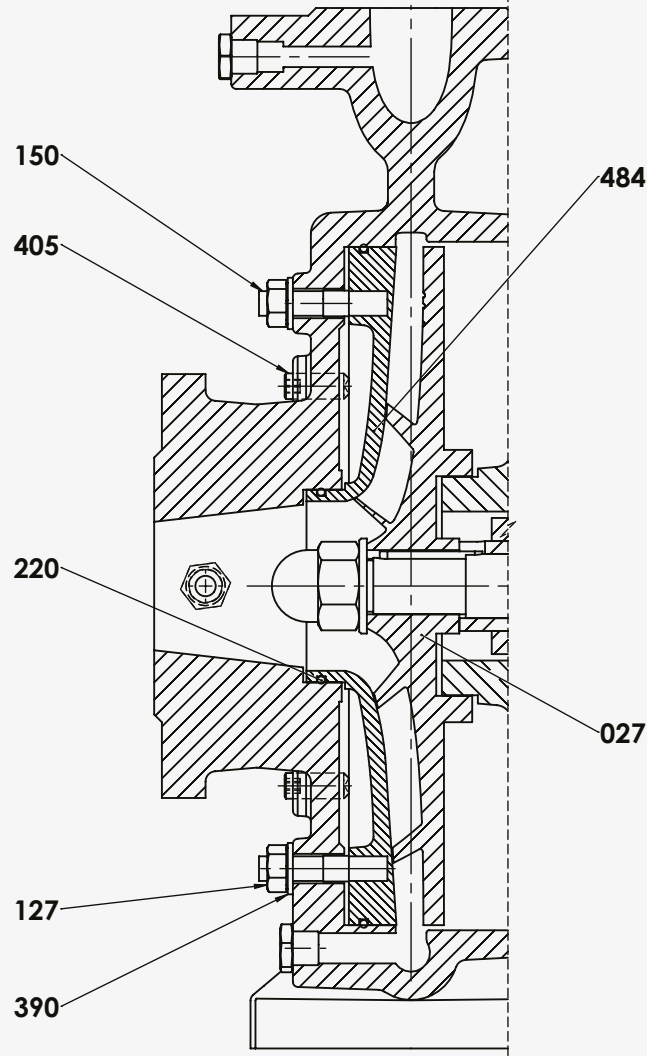

Part List

Parça Listesi

Impeller	029	Çark
Bolt	408	Civata
Front Wear Plate	484	Ön Aşınma Plakası
Rear Wear Plate	485	Arka Aşınma Plakası
Stud Bolt	150	Saplama
Set Screw	405	Setskur
O-ring	220	O-ring
Nut	127	Somun
Washer	390	Rondela
Wear Plate	484	Aşınma Plakası
Impeller	027	Çark

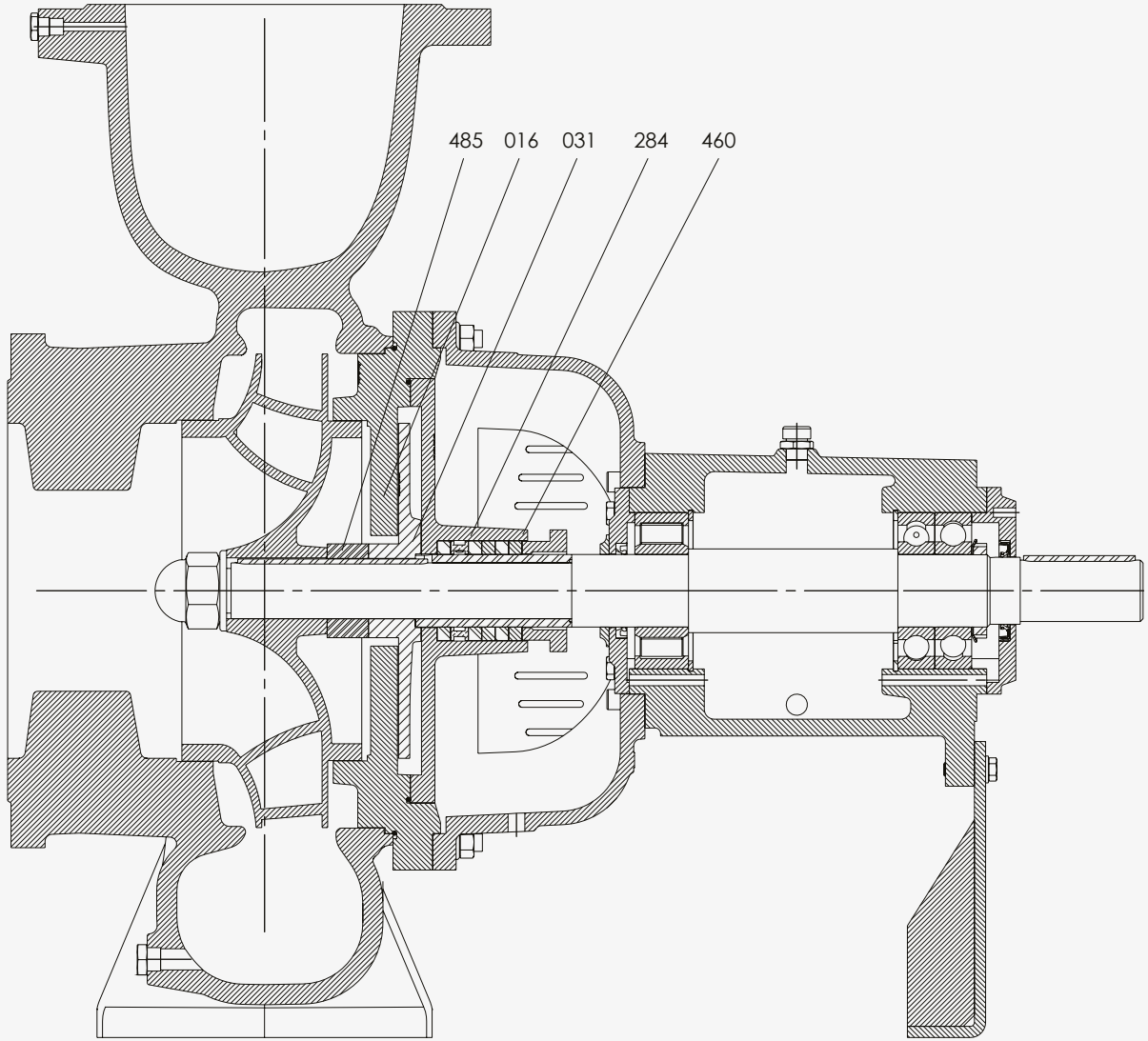

Part List

Parça Listesi

Impeller Setting Sleeve	485	Çark Mesafe Burcu
Expeller Impeller	031	Expeller Çark
Seal Box	284	Salmastra Kutusu
Sealing Setting Sleeve	460	Salmastra Burcu
Diffuser Cover	016	Difüzör Kapak



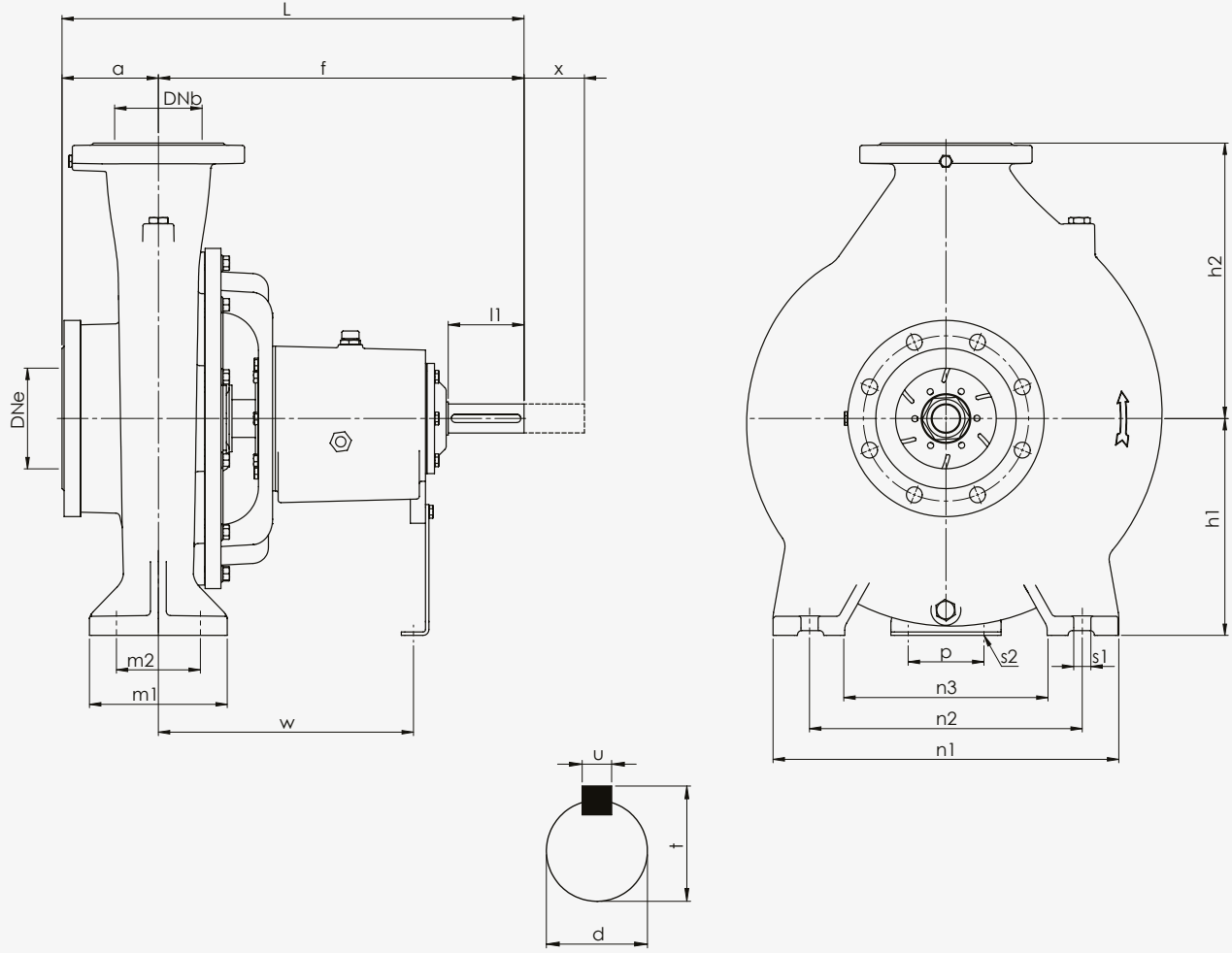

Pump Type / Pompa Tipi		Dimensions / Ölçüler (mm)																					
		Outside Dimensions / Dış Ölçüler						Supporting Foot Dimensions / Ayak Bağlantı Ölçüleri						Shaft Dimensions / Mil Ölçüleri					Spacing / Aralık				
ISO 2858	Other Diğer	DNe	DNb	a	f	L	h1	h2	m1	m2	n1	n2	n3	s1	p	s2	w	d	l1	t	u	x	
32-125		50	32	80	385	465	112	140	100	70	190	140	90	14	110	14	285	24	50	27	8	100	
32-160		50	32	80	385	465	132	160	100	70	240	190	140	14	110	14	285	24	50	27	8	100	
32-200		50	32	80	385	465	160	180	100	70	240	190	140	14	110	14	295	24	50	27	8	100	
32-250		50	32	100	500	600	180	225	125	95	320	250	190	14	110	14	285	32	80	35	10	100	
40-200		65	40	100	385	485	160	180	100	70	265	212	165	14	110	14	285	24	50	27	8	100	
40-250		65	40	100	500	600	180	225	125	95	320	250	190	14	110	14	370	32	80	35	10	100	
50-160		80	50	100	385	485	160	180	100	70	265	212	165	14	110	14	285	24	50	27	8	100	
50-200		80	50	100	385	485	160	200	100	70	265	212	165	14	110	14	285	24	50	27	8	100	
50-250		80	50	125	500	625	180	225	125	95	320	250	190	14	110	14	370	32	80	35	10	100	
50-315		80	50	125	500	625	225	280	125	95	345	280	215	14	110	14	370	32	80	35	10	100	
65-160		100	65	100	500	600	160	200	125	95	280	212	150	14	110	14	370	32	80	35	10	140	
65-200		100	65	100	500	600	180	225	125	95	320	250	190	14	110	14	370	32	80	35	10	140	
65-250		100	65	125	500	625	200	250	160	120	360	280	200	19	110	14	370	32	80	35	10	140	
65-315		100	65	125	530	625	225	280	160	120	400	315	240	19	110	14	370	42	110	45	12	140	

Pump Type / Pompa Tipi		Dimensions / Ölçüler (mm)																					
		Outside Dimensions / Dış Ölçüler							Supporting Foot Dimensions / Ayak Bağlantı Ölçüleri							Shaft Dimensions / Mil Ölçüleri				Spacing / Aralık			
ISO 2858	Other Diğer	DNe	DNb	a	f	L	h1	h2	m1	m2	n1	n2	n3	s1	p	s2	w	d	l1	t	u	x	
80-200		125	80	125	500	625	180	250	125	95	345	280	215	14	110	14	370	32	80	35	10	140	
80-250		125	80	125	500	625	225	280	160	120	400	315	240	19	110	14	370	32	80	35	10	140	
80-315		125	80	125	530	655	250	315	160	120	400	315	240	19	110	14	370	42	110	45	12	140	
80-400		125	80	125	530	655	280	355	160	120	435	355	275	19	110	14	370	42	110	45	12	140	
100-200		125	100	125	500	625	200	280	160	120	360	280	200	19	110	14	370	32	80	35	10	140	
100-250		125	100	140	530	670	225	280	160	120	400	315	240	19	110	14	370	42	110	45	12	140	
100-315		125	100	140	530	670	250	315	160	120	400	315	240	19	110	14	370	42	110	45	12	140	
100-400		125	100	140	530	670	280	355	200	150	500	400	300	23	110	14	370	42	110	45	12	140	
	125-200	150	125	140	500	640	250	315	160	120	400	315	240	19	110	14	370	32	80	35	10	140	
125-250		150	125	140	530	670	250	355	160	120	400	315	240	19	110	14	370	42	110	45	12	140	
125-315		150	125	140	530	670	280	355	200	150	500	400	300	23	110	14	370	42	110	45	12	140	
125-400		150	125	140	530	670	315	400	200	150	500	400	300	23	110	14	370	42	110	45	12	140	
	150-200	200	150	160	545	705	280	355	200	150	550	450	350	23	140	14	381	32	110	45	10	180	
150-250		200	150	160	530	690	280	375	200	150	500	400	300	23	140	14	366	42	110	45	12	180	
150-315		200	150	160	670	830	315	400	200	150	550	450	350	23	140	19	500	48	110	51,5	14	180	
150-400		200	150	160	670	830	315	450	200	150	550	450	350	23	140	19	500	48	110	51,5	14	180	
	150-500	200	150	200	730	820	400	525	250	200	720	600	435	27	140	19	495	55	110	51,5	16	140	
	200-270	250	200	200	630	830	355	450	250	200	600	500	360	23	140	20	515	42	110	51,6	14	200	
	200-315	250	200	190	684	820	355	450	250	200	600	500	360	23	140	20	520	48	110	51,5	14	180	
	200-200	250	200	180	725	905	400	500	250	200	600	500	360	23	140	20	490	55	110	59	16	180	
	200-400	250	200	180	725	905	400	500	250	200	600	500	360	27	140	20	510	55	110	59	16	200	
	200-500	250	200	210	925	1135	400	525	300	240	720	600	435	27	140	20	640	70	140	73	20	180	
	250-350	300	250	230	740	970	400	525	300	240	720	600	435	27	140	20	515	55	110	59	16	200	
	250-400	300	250	255	960	1215	450	550	300	260	660	515	375	27	160	20	675	70	140	73	20	275	
	250-500	300	250	225	940	1165	450	630	300	240	725	600	400	27	140	20	670	70	140	74,5	20	200	

○ (x): Without removing the electric motor and the pump's volute the pump shows the minimum spacing required between the motor and the pump shaft to remove the bearing and rotor assembly. (intermediate bushing coupling application)

(x): Elektrik motorunu ve pompanın salyangozunu sökmeden, pompa yatak ve rotor grubunu yerinden alabilmek için motor ve pompa mili arasındaki gerekli olan minimum boşluğu göstermektedir. (ara burçlu kaplin uygulaması)



FLANGE DIMENSIONS

FLANŞ ÖLÇÜLERİ

DNe / DNb	Suction & Discharge / Emme & Basma (PN 16)			
	Df	k	s	n
32	140	100	19	4
40	150	110	19	4
50	165	125	19	4
65	185	145	19	4
80	200	160	19	8
100	220	180	19	8
125	250	210	19	8
150	285	240	23	8
200	340	295	23	12
250	405	355	28	12
300	460	410	28	12

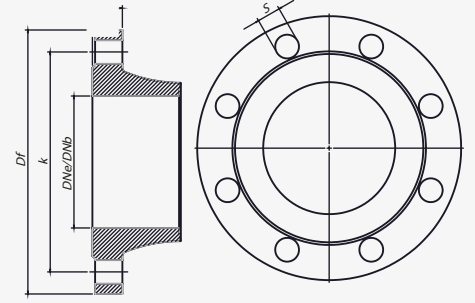

TS EN 1092-2 "n" Number of Holes / Delik Sayısı

SEAL SOLUTIONS

SALMASTRA ÇÖZÜMLERİ

Packing Type / Salmastra Tipi	Packing Specifications / Salmastra Özellikleri	
	Temperature / Sıcaklık	Pressure / Basınç
eMG1	t = -20 °C ... +140 °C	P = 16 Bar (230 PSI)
H12N	t = +100 °C ... +140 °C	P = 25 Bar (363 PSI)
M7N	t = -20 °C ... +220 °C	P = 25 Bar (363 PSI)
M37	t = -20 °C ... +180 °C	P = 10 Bar (145 PSI)
H7N	t = -50 °C ... +220 °C	P = 80 Bar (1160 PSI)
CARTEX - DN	t = -40 °C ... +220 °C	P = 25 Bar (363 PSI)

(*) Optional

*Note: Above datas mentioned according to BURGMANN Brand. Packing can be changed according to customer request.

*Different seal application can be used according to liquid specification.

(*) Opsiyonel

*Not: BURGMANN marka mekanik salmastraya göre belirlenmiştir. Müşteri isteğine göre salmastra marka değişikliği yapılabilir.

*Akışkan cinsi ve çalışma şartlarına göre farklı salmastra seçenekleri uygulanabilir.

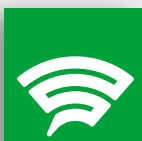



50 YIL
50 Years

50 Yıldır Yanınızdayız
We Have Been With You For 50 Years

DÖKÜM
Casting

Pik Döküm
Cast Iron

Sfero Döküm
Ductile Cast Iron

Paslanmaz Çelik
Stainless Steel

Çelik
Steel

Duplex Çelik
Duplex Steel

Bronz
Bronze

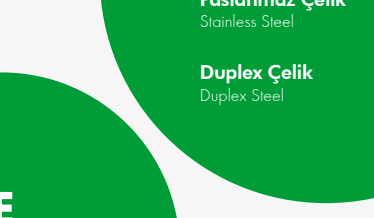

İŞLEME
Machining

CNC - Hassas İşleme - Kalite Kontrol
CNC - Sensitive Machining - Quality Control



KALİTE KONTROL
Quality Control

DENEY
Testing

Her Ürün İle Test Raporu Teslimi
Supply Testing Raport For Each Pump

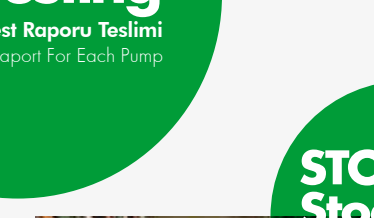
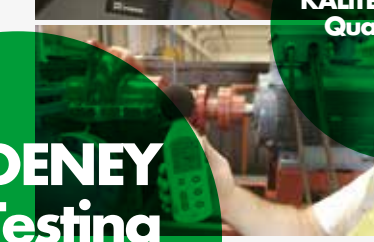
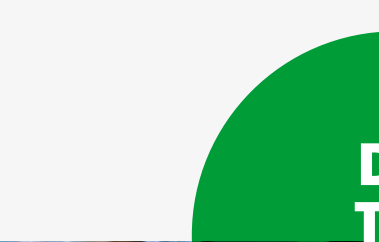

STOK
Stock

1.500.000 Kg İşlenmiş Parça
1.500.000 Kg Machined Part



I'M
PUMP
TECH
NOLOGY

A series of horizontal dashed lines for writing.



TKF-AH SERIES

DPT SERIES

ARS-D SERIES

ARS SERIES

TKF-M SERIES

SP SERIES

TKF-KE SERIES